

SECTION 1

GENERAL

CONTENTS

	Page
Introduction	1-1
Three-View of R22 Helicopter	1-3
Descriptive Data	1-4
Performance Definitions	1-6
Weight and Balance Definitions	1-7
Conversion Tables	1-8

INTENTIONALLY BLANK

**SECTION 1
GENERAL**

INTRODUCTION

This Pilot's Operating Handbook is designed as an operating guide for the pilot. It includes the material required to be furnished to the pilot by FAR 27 and FAR 21. It also contains supplemental data supplied by the helicopter manufacturer.

This handbook is not designed as a substitute for adequate and competent flight instruction or for knowledge of current airworthiness directives, applicable federal air regulations and advisory circulars. Nor is it intended to be a guide for basic flight instruction or a training manual. It should not be used for operational purposes unless kept in a current status.

Assuring that the helicopter is in airworthy condition is the responsibility of the owner. The pilot in command is responsible for determining that the helicopter is safe for flight. The pilot is also responsible for remaining within the operating limitations as outlined by instrument markings, placards, and this handbook.

Since it is very difficult to refer to a handbook while flying a helicopter, the pilot should study the entire handbook and become very familiar with the limitations, performance, procedures and operational handling characteristics of the helicopter before flight.

This handbook has been divided into ten numbered sections. The limitations and emergency procedures have been placed ahead of the normal procedures, performance and other sections to provide easier access to that information. Provisions for expansion of the handbook have been made by the deliberate omission of certain paragraph numbers, figure numbers, item numbers and pages noted as being left blank, intentionally.

THIS PAGE INTENTIONALLY LEFT BLANK

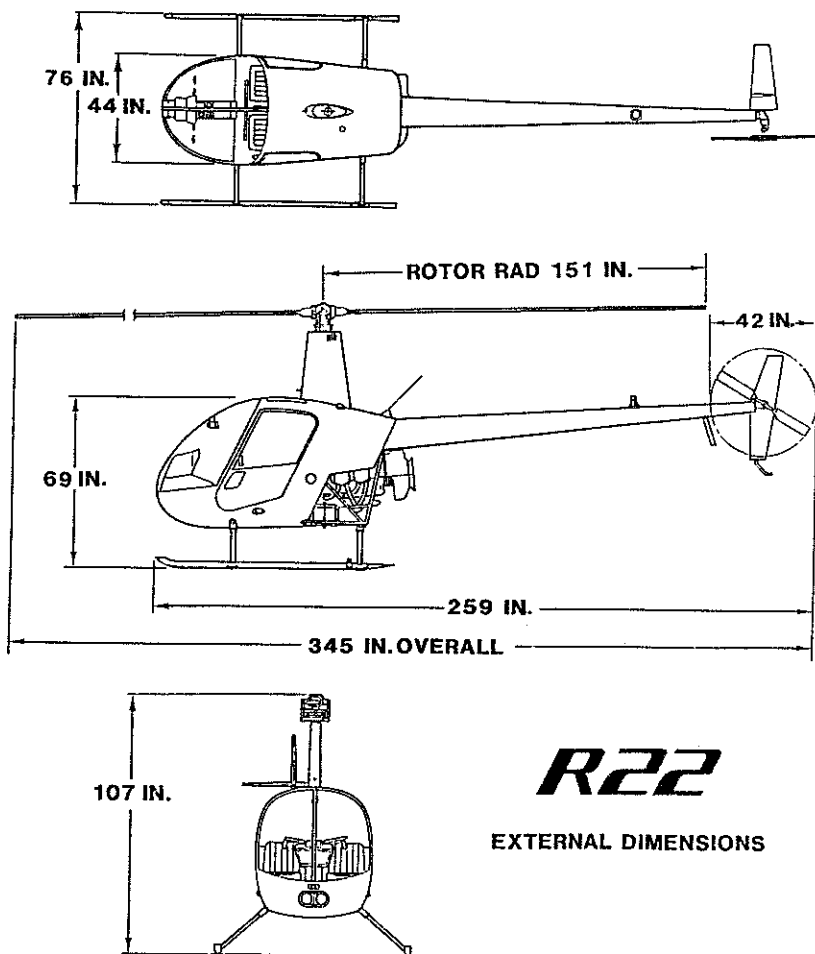

THREE-VIEW OF R22 HELICOPTER

DESCRIPTIVE DATA

MAIN ROTOR

Articulation	Free to teeter and cone, rigid inplane
Number of Blades	2
Diameter	25 feet 2 inches
Blade Chord	7.2 inches (constant)
Blade Twist	-8 degrees
Tip Speed @ 100% RPM	672 FPS

TAIL ROTOR

Articulation	Free to teeter, rigid inplane
Number of Blades	2
Diameter	3 feet 6 inches
Blade Chord	4 inches (constant)
Blade Twist	0 degrees
Precone Angle	1 degree 11 minutes
Tip Speed @ 100% RPM	599 FPS

DRIVE SYSTEM

Engine to Upper Sheave:	Two double Vee-belts with .8536:1 speed reducing ratio
Upper Sheave to Drive Line:	Sprag type overrunning clutch
Drive Line to Main Rotor:	Spiral-bevel gears with 11:47 speed reducing ratio
Drive Line to Tail Rotor:	Spiral-bevel gears with 3:2 speed increasing ratio

DESCRIPTIVE DATA (cont'd)

POWERPLANT

Model: Lycoming O-320 or O-360

Type: Four-cylinder, horizontally-opposed, direct-drive
air-cooled, carbureted, normally-aspirated

Displacement: 319.8 (O-320) or 361.0 (O-360) cubic inches

Normal rating:

O-320-A2B or A2C	150 BHP @ 2700 RPM (Standard R22)
O-320-B2C	160 BHP @ 2700 RPM (R22 HP, Alpha, and Beta)
O-360-J2A	145 BHP (derated) @ 2700 RPM (R22 Beta II)

Maximum continuous rating in R22: 124 BHP at 2652 RPM
(104% on tachometer)

5 m.nute takeoff rating for Beta and
Beta II only: 131 BHP at 2652 RPM

Cooling system: Direct-drive squirrel-cage blower

FUEL

Approved fuel grades and capacity: See page 2-9.

OIL

Approved oil grades and capacity: See page 8-6.

PERFORMANCE DEFINITIONS

IAS	Knots Indicated Airspeed is the speed shown on the airspeed indicator.
KCAS	Knots Calibrated Airspeed is the speed shown on the airspeed indicator corrected for instrument and position error. (See page 5-2 for position error correction.)
KTAS	Knots True Airspeed is the airspeed relative to the undisturbed air. It is the KCAS corrected for pressure altitude and temperature.
V_{ne}	Never-Exceed Airspeed.
V_y	Speed for best rate of climb.
MSL Altitude	Altitude above sea level, in feet, indicated by the altimeter (corrected for position and instrument error) when the barometric subscale is set to the atmospheric pressure existing at sea level.
Pressure Altitude	Altitude, in feet, indicated by the altimeter (corrected for position and instrument error) when the barometric subscale is set to 29.92 inches of mercury (1013.2 mb).
Density Altitude	Altitude, in feet, in ISA conditions at which the air would have the same density (it is the pressure altitude corrected for OAT).
ISA	International Standard Atmosphere exists when, at sea level, the pressure is 29.92 inches of mercury and the temperature is 15°C and the temperature decreases 1.98°C per 1000 feet of altitude.
BHP	Brake Horsepower is the actual power output of the engine.
MAP	Manifold Pressure is the absolute pressure, in inches of mercury, in the engine intake manifold.
RPM	Revolutions Per Minute or speed of the engine or main rotor. (Shown by the R22 Tachometer as a percentage of 2550 engine RPM or 510 main rotor RPM).
MCP	Maximum Continuous Power.
TOP	Takeoff Power (usually for a maximum of 5 minutes).
Critical Altitude	Altitude at which full throttle produces maximum allowable power (MCP or TOP).
TOGW	Takeoff Gross Weight.

PERFORMANCE DEFINITIONS (cont'd)

OAT	Outside Air Temperature
CAT	Carburetor Air Temperature
CHT	Cylinder Head Temperature
GPH	Gallons Per Hour
AGL	Above Ground Level
IGE	In Ground Effect
OGE	Out of Ground Effect
ALT	Alternator

WEIGHT AND BALANCE DEFINITIONS

Reference Datum	An imaginary vertical plane from which all horizontal distances are measured for balance purposes.
Station	A fore-and-aft location along the helicopter fuselage usually given in terms of distance in inches from the reference datum.
Arm	The horizontal distance from the reference datum to the center of gravity (CG) of an item.
Moment	The product of the weight of an item multiplied by its arm. (Moment divided by a constant is used to simplify balance calculations by reducing the number of digits).
Center of Gravity (CG)	The point at which a helicopter would balance if suspended. Its distance from the reference datum is found by dividing the total moment by the total weight of the helicopter.
CG Arm	The arm from the reference datum obtained by adding the helicopter's individual moments and dividing the sum by the total weight.
CG Limits	The extreme center of gravity locations within which the helicopter must be operated at a given weight.
Usable Fuel	Fuel available for flight planning.
Unusable Fuel	Fuel remaining after a runout test has been completed in accordance with governmental regulations.
Standard Empty Weight	Weight of a standard helicopter including unusable fuel, full operating fluids, and full oil.
Basic Empty Weight	Standard empty weight plus weight of installed optional equipment.
Payload	Weight of occupants, cargo, and baggage.
Useful Load	Difference between maximum takeoff weight and basic empty weight.

CONVERSION TABLES**METRIC TO ENGLISH**

<u>Multiply</u>	<u>By</u>	<u>To Obtain</u>
centimeters (cm)	.3937	inches (in)
kilograms (kg)	2.2046	pounds (lb)
kilometers (km)	.5400	nautical miles (nm)
kilometers (km)	.6214	statute miles (mi)
liters (l)	.2642	gallons, U.S. (gal)
liters (l)	1.0567	quarts (qt)
meters (m)	3.2808	feet (ft)

ENGLISH TO METRIC

<u>Multiply</u>	<u>By</u>	<u>To Obtain</u>
feet (ft)	.3048	meters (m)
gallons, U.S.(gal)	3.7854	liters (l)
inches (in)	2.5400	centimeters (cm)
inches (in)	25.4000	millimeters (mm)
nautical miles (nm)	1.8520	kilometers (km)
pounds (lb)	.4536	kilograms (kg)
quarts (qt)	.9464	liters (l)
statute miles (mi)	1.6093	kilometers (km)

SECTION 2
LIMITATIONS
CONTENTS

	Page
General	2-1
Color Code for Instrument Markings	2-1
Airspeed Limits	2-1
Rotor Speed Limits	2-2
Powerplant Limitations	2-2
Weight Limits	2-3
Center of Gravity Limits	2-3
Flight and Maneuver Limitations	2-6
Kinds of Operation Limitations	2-7
Fuel Limitations	2-7
Instrument Markings	2-8
Placards	2-10

INTENTIONALLY BLANK

SECTION 2

LIMITATIONS

GENERAL

Information contained in Section 2 is approved by the Federal Aviation Administration. This section includes operating limitations, instrument markings, and basic placards required for safe operation of the helicopter, its engine, and other standard systems. This helicopter is approved under FAA Type Certificate No. H10WE as Model R22.

COLOR CODE FOR INSTRUMENT MARKINGS

- Red Indicates operating limits. Pointer should not enter red during normal operation.
- Yellow Precautionary or special operating procedure range.
- Green Normal operating range.

AIRSPPEED LIMITS

NEVER-EXCEED AIRSPEED (V_{no})

Up to 3000 feet density altitude: 102 KIAS

Above 3000 feet density altitude, see placards on page 2-11.

ROTOR SPEED LIMITS

	TACHOMETER READING	ACTUAL RPM
Power On		
Maximum	104%	530
Minimum, O-360 engine	101%	515
Minimum, O-320 engine	97%*	495
Power Off		
Maximum	110%	561
Minimum	90%	459

*Tachometers with green arc from 97% to 104% RPM were originally installed in R22s with O-320 engines. Tachometers which show green arc from 101% to 104% RPM are permitted as replacements. Regulations require that limitations indicated by installed tachometer are not exceeded.

POWERPLANT LIMITATIONS

ENGINE

One Lycoming Model O-320 or O-360

OPERATING LIMITATIONS

Engine Maximum Speed	2652 RPM (104%)
Cylinder Head Max Temperature	500°F (260°C)
Oil Maximum Temperature	245°F (118°C)
Oil Pressure**	
Minimum during idle	25 psi
Minimum during flight	55 psi
Maximum during flight	95 psi
Maximum during start & warm-up	115 psi
Oil Quantity, minimum for takeoff	4 qt

Manifold Pressure: See placards on pages 2-10 and 2-11 for MAP schedules.

**These limitations apply to all engines. Earlier oil pressure gages show green arc from 60 to 90 psi and red line at 100 psi. Regulations require that limits indicated by installed gage are not exceeded.

WEIGHT LIMITS

~~Maximum gross weight - Standard & HP 1300 lb (590 kg)~~

Maximum gross weight - Alpha, Beta,
and Beta II 1370 lb (622 kg)

Minimum gross weight 920 lb (417 kg)

Maximum per seat
including baggage compartment 240 lb (109 kg)

Maximum in either baggage compartment 50 lb (23 kg)

Minimum solo pilot plus baggage weight with doors installed
is 130 lb (59 kg) with standard fuel or 135 lb (61 kg) with
aux fuel unless a weight and balance computation shows
CG is within limits. Ballast may be required.

CENTER OF GRAVITY (CG) LIMITS

See figures on pages 2-4 and 2-5. Datum line is 100 inches
forward of main rotor shaft centerline.

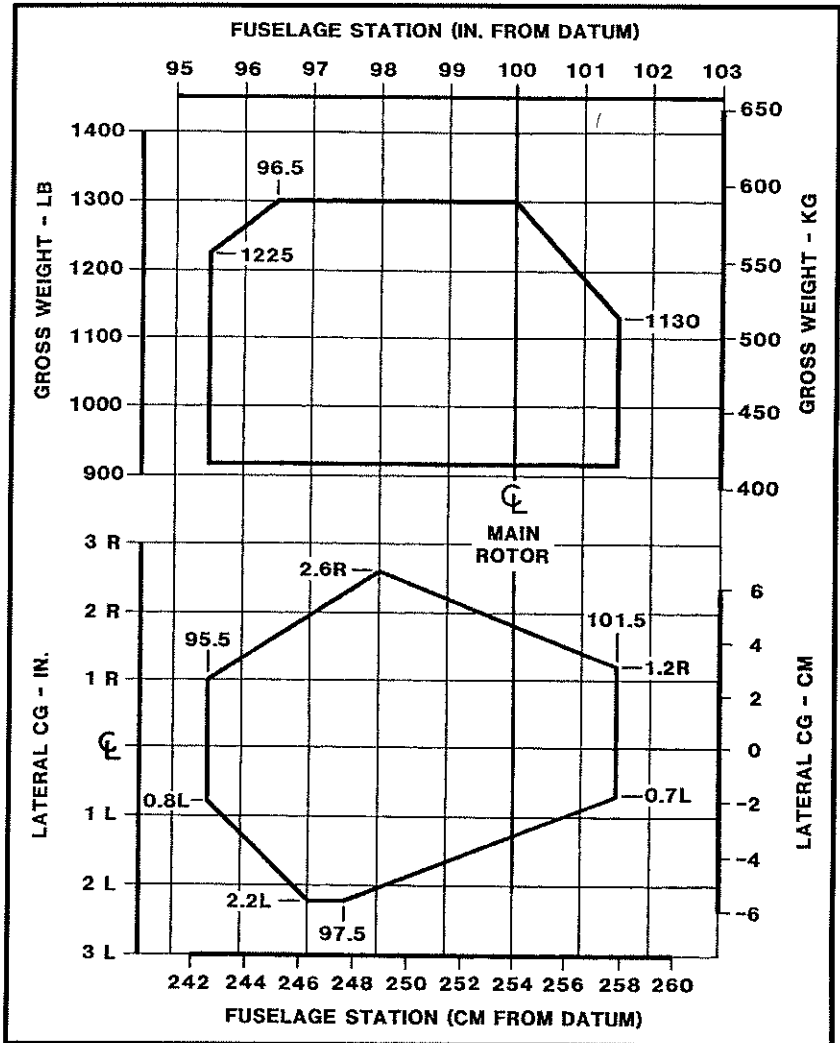

R22 STANDARD AND HP
CENTER OF GRAVITY LIMITS

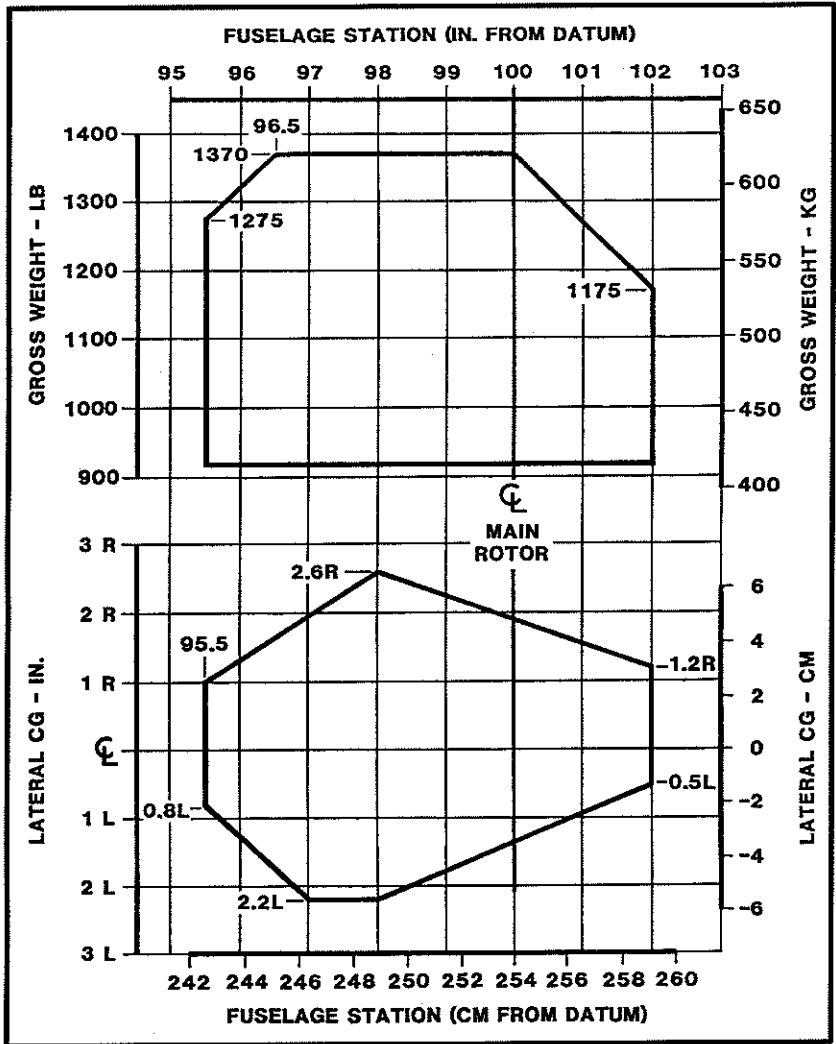

R22 ALPHA, BETA, AND BETA II
CENTER OF GRAVITY LIMITS

FLIGHT AND MANEUVER LIMITATIONS

Aerobatic flight prohibited.

Low-G cyclic pushovers prohibited.

CAUTION

A pushover (forward cyclic maneuver) performed from level flight or following a pull-up causes a low-G (near weightless) condition which can result in catastrophic loss of lateral control. To eliminate a low-G condition, immediately apply gentle aft cyclic. Should a right roll commence during a low-G condition, apply gentle aft cyclic to reload rotor before applying lateral cyclic to stop the roll.

Flight prohibited with governor selected off, with exceptions for in-flight system malfunction or emergency procedures training.

Flight in known icing conditions prohibited.

Maximum operating density altitude 14,000 feet.

Alternator, RPM governor, low rotor RPM warning system, and OAT gage must be operational for flight.

Solo flight from right seat only.

Left seat belt must be buckled.

Minimum crew is one pilot.

Doors-off operation approved with either or both doors removed.

CAUTION

No loose items allowed in cabin during doors-off flight.

CAUTION

Avoid abrupt control inputs. They produce high fatigue stresses and could lead to a premature and catastrophic failure of a critical component.

KINDS OF OPERATION LIMITATIONS

VFR day is approved.

VFR operation at night is permitted only when landing, navigation, instrument, and anti-collision lights are operational. Orientation during night flight must be maintained by visual reference to ground objects illuminated solely by lights on the ground or adequate celestial illumination.

Note: There may be additional requirements in countries outside the U.S.

FUEL LIMITATIONS

APPROVED FUEL GRADES

80/87 grade aviation fuel
O-320-A2B and -A2C engines only (Standard R22)

91/96 grade aviation fuel
All engines

100LL grade aviation fuel
All engines

100/130 grade aviation fuel
O-320-B2C and O-360-J2A engines (HP, Alpha, Beta,
and Beta II)

FUEL CAPACITY

Main tank total capacity: 19.8 US gallons (75 liters)

Main tank usable capacity: 19.2 US gallons (73 liters)

Optional aux tank total
capacity: 10.9 US gallons (41 liters)

Optional aux tank usable
capacity: 10.5 US gallons (40 liters)

INSTRUMENT MARKINGS

AIRSPEED INDICATOR

Green arc	50 to 102 KIAS
Red line	102 KIAS

ROTOR TACHOMETER

Upper red line	110%
Yellow arc	104 to 110%
Green arc, O-360 engine	101 to 104%
Green arc, O-320 engine	97 to 104%*
Yellow arc, O-360 engine	90 to 101%
Yellow arc, O-320 engine	90 to 97%*
Lower red line	90%
Yellow arc	60 to 70%

ENGINE TACHOMETER

Upper red arc	104 to 110%
Green arc, O-360 engine	101 to 104%
Green arc, O-320 engine	97 to 104%*
Lower red arc, O-360 engine	90 to 101%
Lower red arc, O-320 engine	90 to 97%*
Yellow arc	60 to 70%

*Tachometers which show green arc from 101% to 104% RPM may be installed.

INSTRUMENT MARKINGS (cont'd)

OIL PRESSURE*

Lower red line	25 psi
Lower yellow arc	25 to 55 psi
Green arc	55 to 95 psi
Upper yellow arc	95 to 115 psi
Upper red line	115 psi

*Earlier gages show green arc from 60 to 90 psi and upper red line at 100 psi.

OIL TEMPERATURE

Green arc	75 to 245°F (24 to 118°C)
Red line	245°F (118°C)

CYLINDER HEAD TEMPERATURE

Green arc	200 to 500°F (93 to 260°C)
Red line	500°F (260°C)

MANIFOLD PRESSURE

Yellow arcs denote variable MAP limits.
See placards on pages 2-10 and 2-11.

~~Standard R22 (O-320-A2B or A2C Engine)~~

Yellow arc	23.2 to 25.9 in. Hg
Red line	25.9 in. Hg

~~HP and Alpha (O-320-B2C Engine)~~

Yellow arc	21.0 to 24.1 in. Hg
Red line	24.1 in. Hg

~~Beta (O-320-B2C Engine)~~

Yellow arc	21.0 to 25.2 in. Hg
Red line	25.2 in. Hg

~~Beta II (O-360-J2A Engine)~~

Yellow arc	19.6 to 24.1 in. Hg
Red line	24.1 in. Hg

CARBURETOR AIR TEMPERATURE

Yellow arc	-15 to 5°C
------------	------------

PLACARDS

In clear view and readable by pilot in flight:

Standard R22
O-320-A2B or
A2C Engine

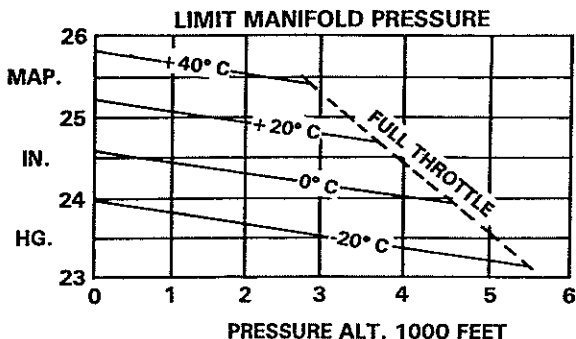

R22 HP and Alpha
O-320-B2C Engine

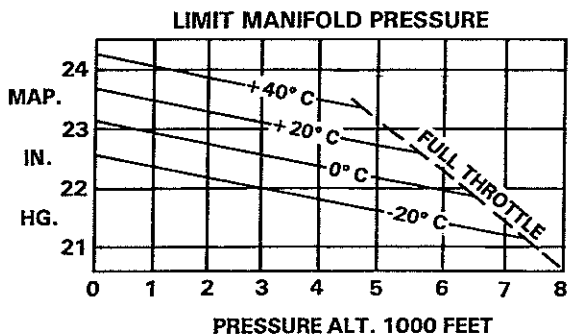

R22 Beta
O-320-B2C Engine

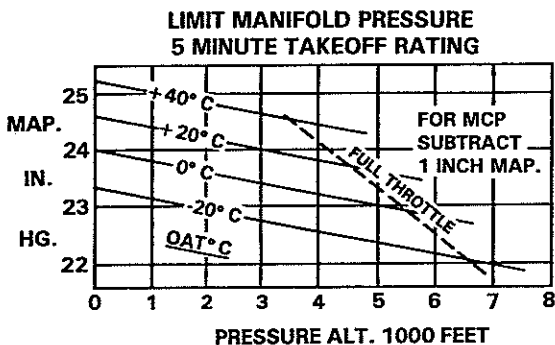

PLACARDS (cont'd)

**R22 Beta II
O-360-J2A Engine**

LIMIT MANIFOLD PRESSURE - IN. HG

MAXIMUM CONTINUOUS POWER

PRESS ALT-FT	OAT - °C						
	-20	-10	0	10	20	30	40
SL	21.5	21.8	22.1	22.3	22.6	22.9	23.2
2000	21.1	21.4	21.6	21.9	22.2	22.5	22.8
4000	20.7	21.0	21.2	21.5	21.8	22.0	22.3
6000	20.3	20.6	20.8	21.1	21.3	21.6	21.9
8000	19.9	20.2	20.4	20.7	20.9	FULL THROTTLE	

FOR MAX TAKEOFF POWER (5 MIN), ADD 0.9 IN. HG

**All R22s
except Beta II**

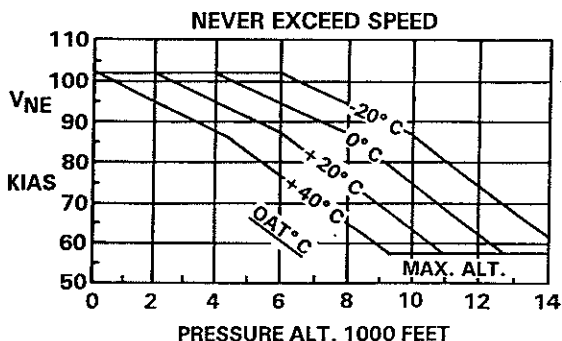

R22 Beta II

NEVER EXCEED SPEED - KIAS

PRESS ALT-FT	OAT - °C						
	-20	-10	0	10	20	30	40
SL	102						
2000							
4000				98	94	91	87
6000		98	94		90	87	82
8000	94	90	86	80	75	69	64
10000	86	80	74	68	62	57	
12000	74	67	61	NO FLIGHT			
14000	61						

PLACARDS (cont'd)

Near main fuel tank filler cap:

Standard R22 (O-320-A2B or -A2C Engine)

FUEL
80/87 MIN GRADE AVIATION GASOLINE
CAP. 19.2 U.S. GAL.

All other models

FUEL
100 OCT. MIN GRADE AVIATION GASOLINE
CAP. 19.2 U.S. GAL.

or

FUEL
91/96 MIN GRADE AVIATION GASOLINE
CAP. 19.2 U.S. GAL.

Near optional aux fuel tank filler cap:

AUX FUEL
100 MIN GRADE AVIATION GASOLINE
CAP. 10.5 U.S. GAL.
TO INSURE FULL FUEL:
TOP OFF FIRST TANK AGAIN AFTER
FILLING SECOND TANK

or

AUX FUEL
91/96 MIN GRADE AVIATION GASOLINE
CAP. 10.5 U.S. GAL.
TO INSURE FULL FUEL:
TOP OFF FIRST TANK AGAIN AFTER
FILLING SECOND TANK

PLACARDS (cont'd)

Near shut-off valve:

**FUEL
ON OFF**

Near main tank fuel gage:

19.2 U.S. GAL

Near optional aux tank fuel gage:

AUX 10.5 U.S. GAL

In clear view of both occupants:

NO SMOKING

On underside of each main rotor blade tip:

**NEVER PULL DOWN
PUSH UP OPPOSITE BLADE**

In clear view of pilot (Alpha, Beta, and Beta II with aft battery installations):

**MINIMUM SOLO PILOT WEIGHT 130 LB
(135 LB WITH FULL AUX FUEL)**

In clear view of pilot:

**THIS ROTORCRAFT APPROVED FOR
DAY AND NIGHT VFR OPERATIONS**

PLACARDS (cont'd)

On left-hand cyclic:

SOLO FROM RIGHT SEAT ONLY

In clear view of pilot:

LOW-G PUSHOVERS PROHIBITED

Inside each baggage compartment:

CAUTION

DO NOT EXCEED ANY OF THE FOLLOWING:

- COMPARTMENT CAPACITY: 50 LB MAX
- COMBINED SEAT PLUS COMPARTMENT: 240 LB MAX
- ROTORCRAFT GROSS WEIGHT LIMIT

SEE ROTORCRAFT FLIGHT MANUAL FOR ADDITIONAL INSTRUCTIONS.

On carburetor air temperature gage:

CAUTION

BELOW 18 IN. MP, IGNORE GAGE
& APPLY FULL CARB HEAT

Near heater push-pull control when heater is installed:

IN CASE OF ENGINE FIRE
PUSH HEATER CONTROL TO OFF

On transponder when altitude encoder is installed:

ALTITUDE ENCODER INSTALLED

R22 LIMITATIONS SECTION

The following limitations (1-3) are to be observed unless the pilot manipulating the controls has logged 200 or more flight hours in helicopters, at least 50 of which must be in the RHC Model R22 helicopter, and has completed the awareness training specified in Special Federal Aviation Regulation (SFAR) No. 73, issued February 27, 1995.

- 1) Flight when surface winds exceed 25 knots, including gusts, is prohibited.
- 2) Flight when surface wind gust spreads exceed 15 knots is prohibited.
- 3) Continued flight in moderate, severe, or extreme turbulence is prohibited.

Adjust forward airspeed to between 60 knots indicated airspeed (KIAS) and $0.7 V_{ne}$ but no lower than 57 KIAS, upon inadvertently encountering moderate, severe, or extreme turbulence.

Note: Moderate turbulence is turbulence that causes: (1) changes in altitude or attitude; (2) variations in indicated airspeed; and (3) aircraft occupants to feel definite strains against seat belts.

INTENTIONALLY BLANK

SECTION 3

EMERGENCY PROCEDURES

CONTENTS

	Page
General	3-1
Definitions	3-1
Power Failure - General	3-1
Power Failure Above 500 Feet AGL	3-2
Power Failure Between 8 Feet and 500 Feet AGL	3-2
Power Failure Below 8 Feet AGL	3-3
Maximum Glide Distance Configuration	3-3
Air Restart Procedure	3-3
Ditching - Power Off	3-4
Ditching - Power On	3-4
Loss of Tail Rotor Thrust During Forward Flight	3-5
Loss of Tail Rotor Thrust During Hover	3-5
Engine Fire During Start on Ground	3-6
Fire in Flight	3-6
Electrical Fire in Flight	3-6
Tachometer Failure	3-7
Governor Failure	3-7
Warning/Caution Lights	3-8
Low RPM Horn & Caution Light	3-10

INTENTIONALLY BLANK

SECTION 3

EMERGENCY PROCEDURES

GENERAL

The information contained in Section 3, Emergency Procedures, is approved by the Federal Aviation Administration.

DEFINITIONS

Land Immediately - Land on the nearest clear area where a safe normal landing can be performed. Be prepared to enter autorotation during the approach, if required.

Land as soon as practical - Land at the nearest airport or other facility where emergency maintenance may be performed.

POWER FAILURE - GENERAL

1. A power failure may be caused by either an engine or drive system failure and will usually be indicated by the low RPM horn.
2. An engine failure may be indicated by a change in noise level, nose left yaw, oil pressure light, or decreasing engine RPM.
3. A drive system failure may be indicated by an unusual noise or vibration, nose right or left yaw, or decreasing rotor RPM while engine RPM is increasing.

CAUTION

Aft cyclic is required when collective is lowered at high speed and forward CG.

CAUTION

Avoid using aft cyclic during touchdown or during ground slide to prevent possible blade strike to tailcone.

POWER FAILURE ABOVE 500 FEET AGL

1. Lower collective immediately to maintain RPM and enter normal autorotation.
2. Establish a steady glide at approximately 65 KIAS (See "Maximum Glide Distance Configuration", page 3-3).
3. Adjust collective to keep RPM in green arc or apply full down collective if light weight prevents attaining above 97%.
4. Select landing spot and, if altitude permits, maneuver so landing will be into wind.
5. A restart may be attempted at pilot's discretion if sufficient time is available (See "Air Restart Procedure", page 3-3).
6. If unable to restart, turn off unnecessary switches and shut off fuel.
7. At about 40 feet AGL, begin cyclic flare to reduce rate of descent and forward speed.
8. At about 8 feet AGL, apply forward cyclic to level ship and raise collective just before touchdown to cushion landing. Touch down in level attitude with nose straight ahead.

NOTE

If power failure occurs at night, do not turn on landing lights above 1000 feet AGL to preserve battery power.

POWER FAILURE BETWEEN 8 FEET AND 500 FEET AGL

1. Takeoff operation should be conducted per the Height-Velocity Diagram in Section 5.
2. If power failure occurs, lower collective immediately to maintain rotor RPM.
3. Adjust collective to keep RPM in green arc or apply full down collective if light weight prevents attaining above 97%.
4. Maintain airspeed until ground is approached, then begin cyclic flare to reduce rate of descent and forward speed.
5. At about 8 feet AGL, apply forward cyclic to level ship and raise collective just before touchdown to cushion landing. Touch down with skids level and nose straight ahead.

POWER FAILURE BELOW 8 FEET AGL

1. Apply right pedal as required to prevent yawing.
2. Allow aircraft to settle.
3. Raise collective just before touchdown to cushion landing.

MAXIMUM GLIDE DISTANCE CONFIGURATION

1. Airspeed approximately 75 KIAS.
2. Rotor RPM approximately 90%.
3. Best glide ratio is about 4:1 or one nautical mile per 1500 feet AGL.

CAUTION

Increase rotor RPM to 97% minimum
when autorotating below 500 feet AGL.

AIR RESTART PROCEDURE

1. Mixture - full rich.
2. Primer (if installed) - down and locked.
3. Throttle - closed, then cracked slightly.
4. Actuate starter with left hand.

CAUTION

Do not attempt restart if engine
malfunction is suspected or before safe
autorotation is established.

DITCHING - POWER OFF

1. Follow same procedures as for power failure over land until contacting water.
2. Apply lateral cyclic when aircraft contacts water to stop blades from rotating.
3. Release seat belt and quickly clear aircraft when blades stop rotating.

DITCHING - POWER ON

1. Descend to hover above water.
2. Unlatch doors.
3. Passenger exit aircraft.
4. Fly to safe distance from passenger to avoid possible injury by blades.
5. Switch off battery and alternator.
6. Roll throttle off into overtravel spring.
7. Keep aircraft level and apply full collective as aircraft contacts water.
8. Apply left lateral cyclic to stop blades from rotating.
9. Release seat belt and quickly clear aircraft when blades stop rotating.

LOSS OF TAIL ROTOR THRUST DURING FORWARD FLIGHT

1. Failure is usually indicated by nose right yaw which cannot be corrected by applying left pedal.
2. Immediately enter autorotation.
3. Maintain at least 70 KIAS airspeed if practical.
4. Select landing site, roll throttle off into overtravel spring and perform autorotation landing.

NOTE

When a suitable landing site is not available, the vertical fin may permit limited controlled flight at very low power settings and airspeeds above 70 KIAS; however, prior to reducing airspeed, re-enter full autorotation.

LOSS OF TAIL ROTOR THRUST DURING HOVER

1. Failure is usually indicated by nose right yaw which cannot be stopped by applying left pedal.
2. Immediately roll throttle off into overtravel spring and allow aircraft to settle.
3. Raise collective just before touchdown to cushion landing.

ENGINE FIRE DURING START ON GROUND

1. Cranking - Continue and attempt to start which would suck flames and excess fuel through carburetor into engine.
2. If engine starts, run at 50-60% RPM for a short time, shut down, and inspect for damage.
3. If engine fails to start, shut off fuel and master battery switch.
4. Extinguish fire with fire extinguisher, wool blanket, or dirt.
5. Inspect for damage.

FIRE IN FLIGHT

1. Enter autorotation.
2. Master battery switch - Off (if time permits).
3. Cabin heat - Off (if installed and time permits).
4. Cabin vent - On (if time permits).
5. If engine is running, perform normal landing and immediately shut off fuel valve.
6. If engine stops running, shut off fuel valve and execute autorotation landing as described on pages 3-1 and 3-2.

ELECTRICAL FIRE IN FLIGHT

1. Master battery switch - Off.
2. Alt switch - Off.
3. Land immediately.
4. Extinguish fire and inspect for damage.

CAUTION

Low RPM warning system and governor are inoperative with master battery and alternator switches both off.

TACHOMETER FAILURE

If rotor or engine tach malfunctions in flight, use remaining tach to monitor RPM. If it is not clear which tach is malfunctioning or if both tachs malfunction, allow governor to control RPM and land as soon as practical.

NOTE

Each tach, the governor, and the low RPM warning horn are on separate circuits. Either the battery or the alternator can independently supply power to the tachs. A special circuit allows the battery to supply power to the tachs even if the master battery switch is off.

GOVERNOR FAILURE

If the engine RPM governor malfunctions, grip throttle firmly to override the governor, then switch governor off. Complete flight using manual throttle control.

WARNING/CAUTION LIGHTS

NOTE

If a light causes excessive glare at night, bulb may be unscrewed or circuit breaker pulled to eliminate glare during landing.

- OIL** Indicates loss of engine power or oil pressure. Check engine tach for power loss. Check oil pressure gage and, if pressure loss is confirmed, land immediately. Continued operation without oil pressure will cause serious engine damage and engine failure may occur.
- MR TEMP** Indicates excessive temperature of main rotor gearbox. See note below.
- MR CHIP** Indicates metallic particles in main rotor gearbox. See note below.
- TR CHIP** Indicates metallic particles in tail rotor gearbox. See note below.

NOTE

If light is accompanied by any indication of a problem such as noise, vibration, or temperature rise, land immediately. If there is no other indication of a problem, land as soon as practical.

Break-in fuzz will occasionally activate chip lights. If no metal chips or slivers are found on detector plug, clean and reinstall (tail rotor gearbox must be refilled with new oil). Hover for at least 30 minutes. If chip light comes on again, replace gearbox before further flight.

WARNING/CAUTION LIGHTS (cont'd)

LOW FUEL Indicates approximately one gallon of usable fuel remaining. The engine will run out of fuel after five minutes at cruise power.

CAUTION

Do not use LOW FUEL warning light as a working indication of fuel quantity.

CLUTCH Indicates that clutch actuator circuit is on, either engaging or disengaging the clutch. When the switch is in the ENGAGE position, the light stays on until the belts are properly tensioned. Never take off before the light goes out.

NOTE

The clutch light may come on momentarily during run-up or during flight to retension the belts as they warm-up and stretch slightly. This is normal. If, however, the light flickers or comes on in flight and does not go out within 7 or 8 seconds, pull the CLUTCH circuit breaker, reduce power, and land immediately. Be prepared to enter autorotation. Inspect drive system for a possible malfunction.

ALT Indicates low voltage and possible alternator failure. Turn off nonessential electrical equipment and switch ALT off and back on after one second to reset overvoltage relay. If light stays on, land as soon as practical. Continued flight without functioning alternator can result in loss of electronic tachometer, producing a hazardous flight condition.

WARNING/CAUTION LIGHTS (cont'd)

BRAKE Indicates rotor brake is engaged. Release immediately in flight or before starting engine.

STARTER-ON Indicates starter motor is engaged. If light does not go out when ignition switch is released from start position, immediately pull mixture to idle cut-off and turn master switch off. Have starter motor serviced.

GOV OFF (If installed) Indicates engine RPM throttle governor is off.

CARBON MONOXIDE (If installed) Indicates elevated levels of carbon monoxide (CO) in cabin. Open nose and door vents and shut off heater. If hovering, land or transition to forward flight. If symptoms of CO poisoning (headache, drowsiness, dizziness) accompany light, land immediately.

LOW RPM HORN & CAUTION LIGHT

A horn and an illuminated caution light indicate that rotor RPM may be below safe limits. To restore RPM, immediately roll throttle on, lower collective and, in forward flight, apply aft cyclic. Horn and caution light are disabled when collective is full down.

R22 EMERGENCY PROCEDURES SECTION

1) RIGHT ROLL IN LOW "G" CONDITION

Gradually apply aft cyclic to restore positive "G" forces and main rotor thrust. Do not apply lateral cyclic until positive "G" forces have been established.

2) UNCOMMANDED PITCH, ROLL, OR YAW RESULTING FROM FLIGHT IN TURBULENCE.

Gradually apply controls to maintain rotor RPM, positive "G" forces, and to eliminate sideslip. Minimize cyclic control inputs in turbulence; do not overcontrol.

3) INADVERTENT ENCOUNTER WITH MODERATE, SEVERE, OR EXTREME TURBULENCE.

If the area of turbulence is isolated, depart the area; otherwise, land the helicopter as soon as practical.

INTENTIONALLY BLANK

**SECTION 4
NORMAL PROCEDURES**

CONTENTS

	Page
General	4-1
Airspeeds for Safe Operation	4-1
Daily or Preflight Checks	4-1
Before Starting Engine	4-6
Starting Engine and Run-up	4-7
Takeoff Procedure	4-8
Cruise	4-8
Doors-Off Operation	4-9
Practice Autorotation - Power Recovery	4-9
Practice Autorotation - With Ground Contact	4-10
Use of Carburetor Heat	4-11
Use of Carb Heat Assist	4-11
Approach and Landing	4-12
Shutdown Procedure	4-12
Noise Abatement	4-13

INTENTIONALLY BLANK

SECTION 4

NORMAL PROCEDURES

GENERAL

Information contained in Section 4 is approved by the Federal Aviation Administration.

AIRSPEDS FOR SAFE OPERATION

Takeoff & Climbs	60 KIAS
Maximum Rate of Climb (V_y)	53 KIAS
Maximum Range	83 KIAS*
Landing Approach	60 KIAS
Autorotation	65 KIAS*

*Certain conditions may require lower airspeeds. See placards on page 2-11.

DAILY OR PREFLIGHT CHECKS

Remove any temporary covers and, in cold weather, remove even small accumulations of frost, ice, or snow. Check maintenance records to be sure aircraft is airworthy. Check general condition of aircraft and verify no leaks, discoloration due to heat, dents, chafing, galling, nicks, corrosion, or cracks. Also verify no fretting at seams where parts are joined together. Fretting of aluminum parts produces a fine black powder while fretting of steel parts produces a reddish brown or black residue. Verify Telatemps show no unexplained temperature increases during prior flight.

DAILY OR PREFLIGHT CHECKS (cont'd)

1. Cowl Door

Master switch	On
Oil pressure and alternator lights	On
Warning light test switches	Push to test
Fuel quantity	Check gages
Master switch	Off
Aux fuel tank quantity	Check
Fuel filler cap	Tight
Aux fuel tank	No leaks
Aux fuel drain	Sample
Gearbox oil	Full, no leaks
Rotor brake	Actuation normal
Flex coupling	No cracks, nuts tight
Yoke flanges	No cracks
Gearbox Telatemp	Normal
Sprag clutch	No leaks
Static source	Clear
Control rod ends	Free without looseness
Steel tube frame	No cracks
All fasteners	Tight
Tail rotor control	No interference
Cowl door	Latched

2. Engine Right Side

Carb air ducts	Secure
Carb heat scoop	Secure
Engine sheet metal	No cracks
Electrical terminals	Tight
Fuel line	No leaks
Oil cooler door	Check
Oil lines	No leaks or chafing
Exhaust system	No cracks
Engine general condition	Check
V-belt condition	Check
V-belt slack	Check
Sprag clutch	No leaks
Upper bearing	No leaks
Telatemp - upper bearing	Normal

DAILY OR PREFLIGHT CHECKS (cont'd)

2. Engine Right Side (cont'd)

Lower sheave groove wear Smooth & uniform
Flex coupling No cracks, nuts tight
Yoke flanges No cracks
Steel tube frame No cracks
Tail rotor control No interference

3. Engine Rear

Cooling fan nut Pin in line with marks
Cooling fan No cracks
Fan scroll No cracks
Telatemp - lower bearing Normal
Lower bearing No leaks

4. Empennage

Tail surfaces No cracks
Fasteners Tight
Position light Check

5. Tail Rotor

Gearbox Telatemp Normal
Gearbox Oil visible, no leaks
Blades Clean and no damage/cracks
Pitch links No looseness
Teeter bearings Check condition
Teeter bearing bolt Does not rotate
Control bellcrank Free without looseness

6. Tailcone

Rivets Tight
Skins No cracks or dents
Strobe light condition Check
Antenna Check
Attachment bolts Tight

DAILY OR PREFLIGHT CHECKS (cont'd)

7. Engine Left Side

- Engine oil 4-6 qt
- Oil filter (if installed) Secure, no leaks
- Fuel lines No leaks
- Gascolator drain Sample
- Throttle linkage Operable
- Battery and relay (if located here) Secure
- Alternator belt tension Check
- Steel tube frame No cracks
- Engine sheet metal No cracks
- Exhaust system No cracks
- Engine general condition Check

8. Fuel tank (Main)

- Quantity Check
- Filler cap Tight
- Leakage None
- Drain Sample

9. Main Rotor

CAUTION

Do not pull rotor blades down as damage may occur. To lower one blade, push opposite blade up.

- Blades Clean and no damage/cracks

CAUTION

Verify erosion on lower surface of blades has not exposed skin-to-spar bond line. Reference Rotor Systems description in Section 7.

- Pitch change boots No leaks
- Main hinge bolts Cotter pins installed
- All rod ends Free without looseness
- Pitch link jam nuts Tight
- Pitch link safety wire Secure
- All fasteners Tight
- Swashplate scissors No excessive looseness

DAILY OR PREFLIGHT CHECKS (cont'd)

10. Fuselage Left Side
Baggage compartment Check
Removable controls Secure if installed
Collective control Clear
Seat Belt Check condition and fastened
Door Unlocked and latched
Door hinge safety pin Installed
Landing gear Check
Ground handling wheel Removed
Position light Check
11. Nose Section
Pitot tube Clear
Windshield condition and cleanliness Check
Fresh air vent Clear
Landing lights Check
12. Fuselage Right Side
Landing gear Check
Ground handling wheel Removed
Position light Check
Door hinge safety pin Installed
Baggage compartment Check
13. Cabin Interior
Loose articles Removed or stowed
Seat belt Check condition
Instruments, switches, and controls Check condition
Clock Functioning

CAUTION

For helicopters with removable controls, remove left seat controls if person in that seat is not a rated helicopter pilot.

CAUTION

Be sure rotor blades are approximately level to avoid possible tailcone strike.

DAILY OR PREFLIGHT CHECKS (cont'd)

CAUTION

When flying solo, fill left baggage compartment to capacity before using right compartment. Avoid placing objects in compartments which could injure occupant if seat collapses during a hard landing.

CAUTION

Shorter pilots may require cushion to obtain full travel of all controls. When using cushion, verify aft cyclic travel is not restricted.

BEFORE STARTING ENGINE

Seat belts	Fastened
Fuel shut-off valve	On
Cyclic/collective friction	Off
Cyclic, collective, pedals	Full travel free
Throttle	Full travel free
Collective	Full down, friction on
Cyclic neutral	Friction on
Pedals	Neutral
Landing light	Off
Governor	On
Circuit breakers	In
Carb heat	Off
Mixture	Full rich
Mixture guard*	Installed
Primer (if installed)	Down and locked
Clutch	Disengaged
Altimeter	Set
Rotor brake	Disengaged

*Mixture guard is not used on aircraft with vernier mixture control on console face.

STARTING ENGINE AND RUN-UP

Throttle twists for priming	As required
Throttle	Closed
Master switch	On
Area	Clear
Strobe light	On
Ignition switch	Start, then Both
Starter-On light	Out
Set engine RPM	50 to 60%
Clutch switch	Engaged
Blades turning	Less than 5 seconds
Alternator switch	On
Oil pressure within 30 sec.	25 psi minimum
Avionics, headsets	On
Wait for clutch light	Out
Warm-up RPM	70 to 75%
Engine gages	Green
Mag drop at 75% RPM	7% max in 2 sec
Carb heat check	CAT rise/drop
Sprag clutch check from 75% RPM . . .	Needles split
Doors	Closed and latched
Limit MAP chart	Check
Cyclic/collective friction	Off
Governor On, increase throttle	RPM 102-104%
Warning lights	Out
Lift collective slightly, reduce RPM. .	Horn/light at 97%

CAUTION

Avoid continuous operation at rotor speed of 60 to 70% to minimize tail resonance.

CAUTION

On slippery surfaces, be prepared to counter nose-right rotation with left pedal as governor increases RPM.

STARTING ENGINE AND RUN-UP (Cont'd)

NOTE

During run-up and shutdown, pilot should uncover right ear, open right door, and listen for unusual bearing noise. Failing bearings will produce an audible whine or growl well before final failure.

TAKEOFF PROCEDURE

1. Verify governor on, RPM stabilized at 102 to 104%.
2. Clear area. Slowly raise collective until aircraft is light on skids. Reposition cyclic as required for equilibrium, then gently lift aircraft into hover.
3. Check gages in green, lower nose, and accelerate to climb speed following profile shown by height-velocity diagram in Section 5. If RPM drops below 102%, lower collective.

CRUISE

1. Adjust carb heat if required. (See page 4-11.)
2. Verify RPM near top of green arc.
3. Set manifold pressure with collective for desired power.
4. Pull RT TRIM knob.
5. Verify gages in green, warning lights out.

CAUTION

Exercise extreme care never to inadvertently pull mixture control as engine stoppage will result.

CAUTION

Inflight leaning with engine mixture control is not recommended. Engine stoppage may result as there is no propeller to keep engine turning should overleaning occur.

DOORS-OFF OPERATION

Avoid removing left door to protect tail rotor from loose objects. If left door must be removed, warn passenger to secure loose objects and to keep head and arms inside cabin to avoid high velocity airstream.

PRACTICE AUTOROTATION - POWER RECOVERY

1. Lower collective to down stop and adjust throttle as required for small tachometer needle separation.

CAUTION

To avoid inadvertent engine stoppage, do not chop throttle to simulate a power failure. Always roll throttle off smoothly for small visible needle split.

NOTE

Governor is inactive below 80% engine RPM regardless of governor switch position.

NOTE

When entering autorotation from above 4000 feet, reduce throttle slightly before lowering collective to prevent engine overspeed.

2. Raise collective as required to keep rotor RPM from going above green arc and adjust throttle for small needle separation.
3. Keep RPM in green arc and airspeed 60 to 70 KIAS.
4. At about 40 feet AGL, begin cyclic flare to reduce rate of descent and forward speed.
5. At about 8 feet AGL, apply forward cyclic to level aircraft and raise collective to stop descent. Add throttle if required to keep RPM in green arc.

PRACTICE AUTOROTATION - WITH GROUND CONTACT

If practice autorotations with ground contact are required for demonstration purposes, perform in same manner as power recovery autorotations except:

Prior to cyclic flare, roll throttle off into detent spring and hold it against the hard stop until autorotation is complete. (This prevents throttle correlator from adding power when collective is raised.)

Always contact ground with skids level and nose straight ahead.

CAUTION

The R22 has a light, low-inertia rotor system. Most of the energy required for an autorotation is stored in the forward momentum of the aircraft, not in the rotor. Therefore, a well-timed cyclic flare is required and rotor RPM must be kept in the green until just before ground contact.

CAUTION

During simulated engine failures, a rapid decrease in rotor RPM will occur, requiring immediate lowering of collective control to avoid dangerously low rotor RPM. Catastrophic rotor stall could occur if the rotor RPM ever drops below 80% plus 1% per 1000 feet of altitude.

NOTE

When practice autorotations are made with ground contact, rapid wear of landing gear skid shoes occurs. Inspect periodically and replace when minimum shoe thickness is .06 inches (1.5 mm).

USE OF CARBURETOR HEAT

When conditions conducive to carburetor ice are known or suspected to exist, such as fog, rain, high humidity, or when operating near water, use carburetor heat as follows:

At power settings above 18 inches MAP, apply carburetor heat as required to keep CAT gage needle out of yellow arc.

At power settings below 18 inches MAP, ignore gage and apply full carburetor heat (CAT gage does not indicate correct carburetor temperature below 18 inches MAP).

CAUTION

The pilot may be unaware of carburetor ice formation as the governor will automatically increase throttle and maintain constant manifold pressure and RPM. Therefore, the pilot must apply carburetor heat as required whenever icing conditions are suspected.

USE OF CARB HEAT ASSIST

A carburetor heat assist device is installed on R22s with O-360 engines. The carb heat assist correlates application of carburetor heat with changes in collective setting to reduce pilot work load. Lowering collective mechanically adds heat and raising collective reduces heat. Collective input is transmitted through a friction clutch which allows the pilot to override the system and increase or decrease heat as required. A latch is provided at the control knob to lock carburetor heat off when not required. It is recommended that the control knob be unlatched (to activate carb heat assist) whenever OAT is between 80°F (27°C) and 25°F (-4°C) and the difference between dew point and OAT is less than 20 F° (11 C°). Readjust carburetor heat as necessary following any change in power.

APPROACH AND LANDING

1. Make final approach into wind at lowest practical rate of descent with initial airspeed of 60 knots.
2. Reduce airspeed and altitude smoothly to hover. (Be sure rate of descent is less than 300 FPM before airspeed is reduced below 30 KIAS.)
3. From hover, lower collective gradually until ground contact.
4. After initial ground contact, lower collective to full down position.

CAUTION

When landing on a slope, return cyclic control to neutral before final reduction of rotor RPM.

CAUTION

Never leave helicopter flight controls unattended while engine is running.

SHUTDOWN PROCEDURE

Collective down, RPM 70-75% Friction on
Cyclic and pedals neutral Friction on
CHT drop Throttle closed
Clutch switch Disengage
Wait 30 seconds Pull idle cut-off
Mixture guard Back on mixture
Wait 30 seconds Apply rotor brake
Clutch light off Ignition and master switches off

CAUTION

Do not slow rotor by raising collective during shutdown. Blades may flap and strike tailcone.

NOISE ABATEMENT

To improve the quality of our environment and to dissuade overly restrictive ordinances against helicopters, it is imperative that every pilot minimize noise irritation to the public. Following are several techniques which should be employed when possible.

1. Avoid flying over outdoor assemblies of people. When this cannot be avoided, fly as high as practical, preferably over 2000 feet AGL.
2. Avoid blade slap. Blade slap usually occurs during shallow high-speed descents, especially during turns. It can be avoided by using slower, steeper descents. With the right door removed, the pilot can easily determine those flight conditions which produce blade slap and develop piloting techniques to eliminate or reduce it.
3. When departing from or approaching a landing site, avoid prolonged flight over noise-sensitive areas. Always fly above 500 feet AGL and preferably above 1000 feet AGL.
4. Repetitive noise is far more irritating than a single occurrence. If you must fly over the same area more than once, vary your flight path to not overfly the same buildings each time.
5. When overflying populated areas, look ahead and select the least noise-sensitive route.

NOTE

Above procedures do not apply where they would conflict with Air Traffic Control clearances or instructions or when, in the pilot's judgment, they would result in an unsafe flight path.

INTENTIONALLY BLANK

R22 NORMAL PROCEDURES SECTION

NOTE

Until the FAA completes its research into the conditions and aircraft characteristics that lead to main rotor blade/fuselage contact accidents, and corrective type design changes and operating limitations are identified, Model R22 pilots are strongly urged to become familiar with the following information and comply with these recommended procedures.

Main Rotor Stall: Many factors may contribute to main rotor stall and pilots should be familiar with them. Any flight condition that creates excessive angle of attack on the main rotor blades can produce a stall. Low main rotor RPM, aggressive maneuvering, high collective angle (often the result of high-density altitude, over-pitching [exceeding power available] during climb, or high forward airspeed) and slow response to the low main rotor RPM warning horn and light may result in main rotor stall. The effect of these conditions can be amplified in turbulence. Main rotor stall can ultimately result in contact between the main rotor and airframe. Additional information on main rotor stall is provided in the Robinson Helicopter Company Safety Notices SN-10, SN-15, SN-20, SN-24, SN-27, and SN-29.

Mast Bumping: Mast bumping may occur with a teetering rotor system when excessive main rotor flapping results from low "G" (load factor below 1.0) or abrupt control input. A low "G" flight condition can result from an abrupt cyclic pushover in forward flight. High forward airspeed, turbulence, and excessive sideslip can accentuate the adverse effects of these control movements. The excessive flapping results in the main rotor hub assembly striking the main rotor mast with subsequent main rotor system separation from the helicopter.

To avoid these conditions, pilots are strongly urged to follow these recommendations:

- 1) Maintain cruise airspeeds between 60 KIAS and less than 0.9 Vne, but no lower than 57 KIAS.
- 2) Use maximum "power-on" RPM at all times during powered flight.
- 3) Avoid sideslip during flight. Maintain in-trim flight at all times.
- 4) Avoid large, rapid forward cyclic inputs in forward flight, and abrupt control inputs in turbulence.

INTENTIONALLY BLANK

SECTION 5
PERFORMANCE
CONTENTS

	Page
General	5-1
Demonstrated Operating Temperature	5-1
Airspeed Calibration	5-2
Density Altitude Chart	5-3
IGE Hover Ceiling Vs Gross Weight	
R22 Standard	5-4
R22 HP, Alpha, and Beta	5-5
R22 Beta II	5-6
OGE Hover Ceiling Vs Gross Weight	
R22 Standard	5-7
R22 HP and Alpha	5-8
R22 Beta	5-9
R22 Beta II	5-10
Height-Velocity Diagram	5-11

INTENTIONALLY BLANK

SECTION 5
PERFORMANCE

GENERAL

The information contained in Section 5 is approved by the Federal Aviation Administration.

Hover controllability has been substantiated in 17 knot wind from any direction up to 9,800 feet density altitude. Refer to IGE hover performance data for allowable gross weight.

Indicated airspeed (KIAS) shown on graphs assumes zero instrument error.

CAUTION

The performance data presented in this section was obtained under ideal conditions. Performance under other conditions may be substantially less.

NOTE

Hover performance data given is with carburetor heat off. Full carburetor heat reduces hover ceilings by up to 2000 feet.

DEMONSTRATED OPERATING TEMPERATURE

Satisfactory engine cooling has been demonstrated to an outside air temperature of 38°C (100°F) at sea level or 23°C (41°F) above ISA at altitude.

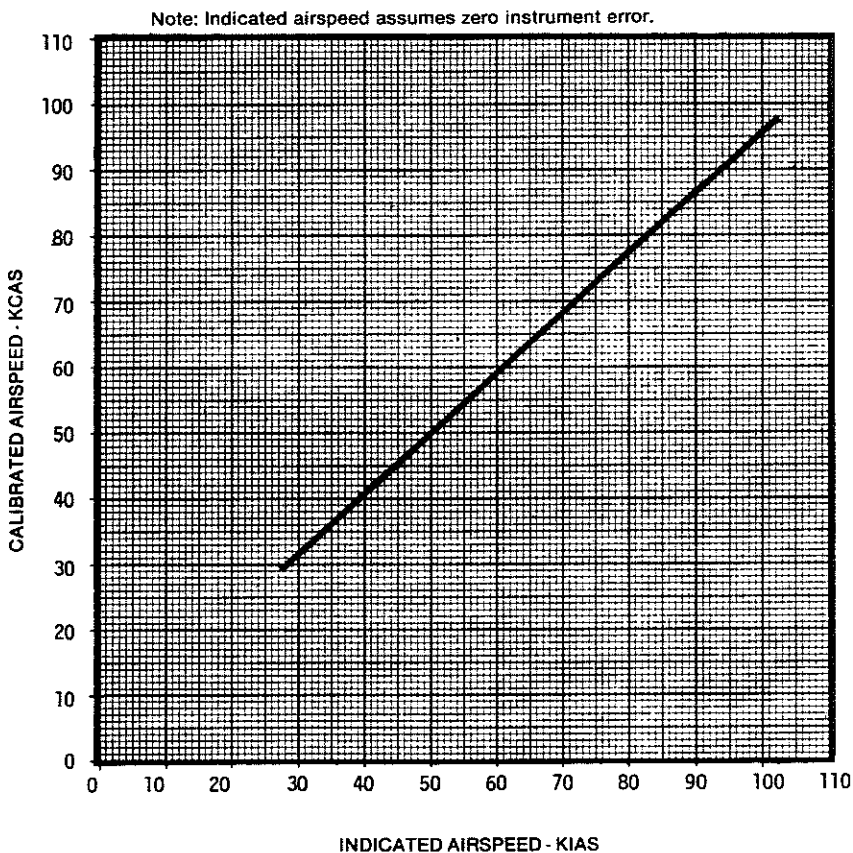

AIRSPEED CALIBRATION CURVE

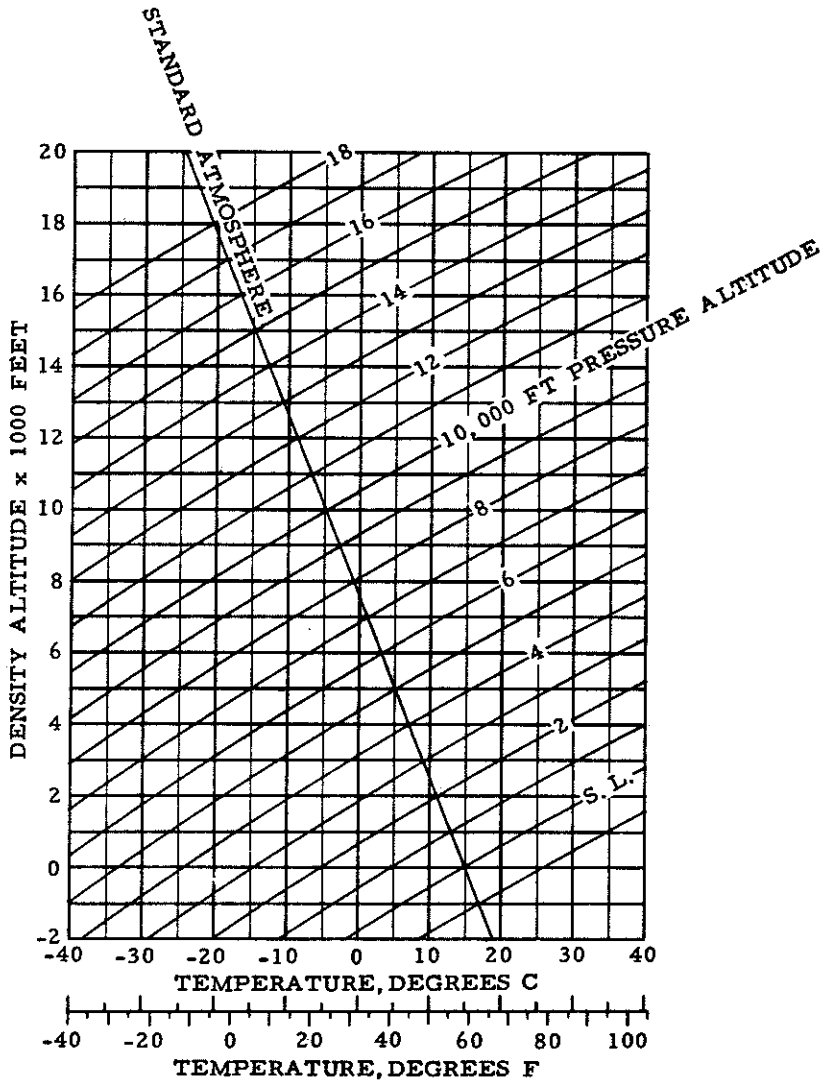

DENSITY ALTITUDE CHART

IN GROUND EFFECT AT 2 FOOT SKID CLEARANCE
FULL THROTTLE AND 104% RPM

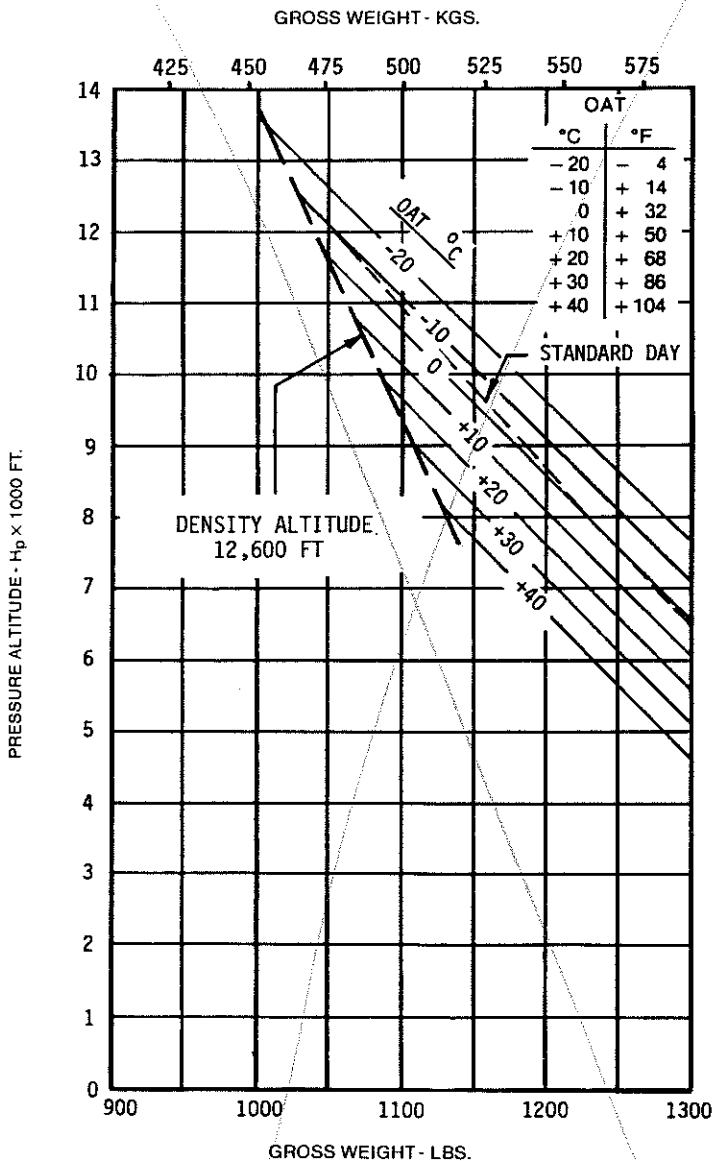

R22 STANDARD
O-320-A2B OR A2C ENGINE

IGE HOVER CEILING VS. GROSS WEIGHT

IN GROUND EFFECT AT 2 FOOT SKID CLEARANCE
FULL THROTTLE
104% RPM
ZERO WIND

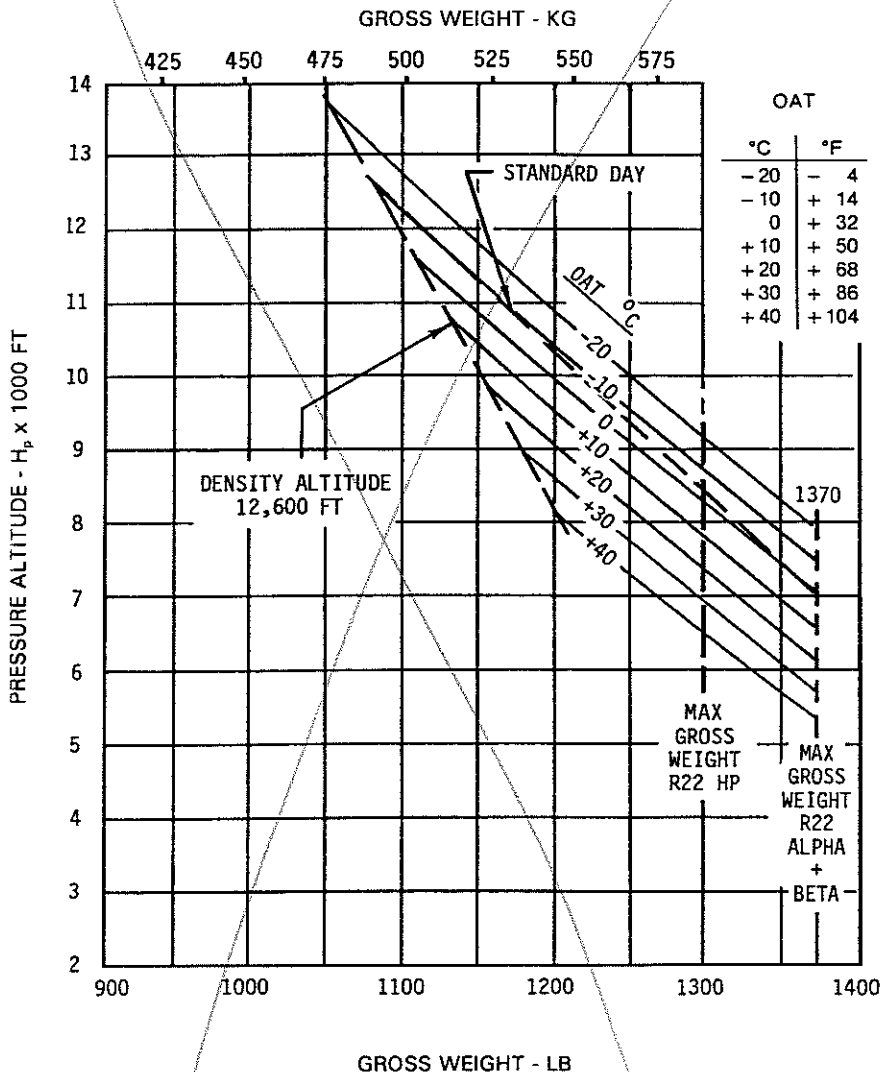

**R22 HP, ALPHA, & BETA
O-320-B2C ENGINE**

IGE HOVER CEILING VS. GROSS WEIGHT

IN GROUND EFFECT AT 2 FOOT SKID CLEARANCE
FULL THROTTLE
103-104% RPM
ZERO WIND

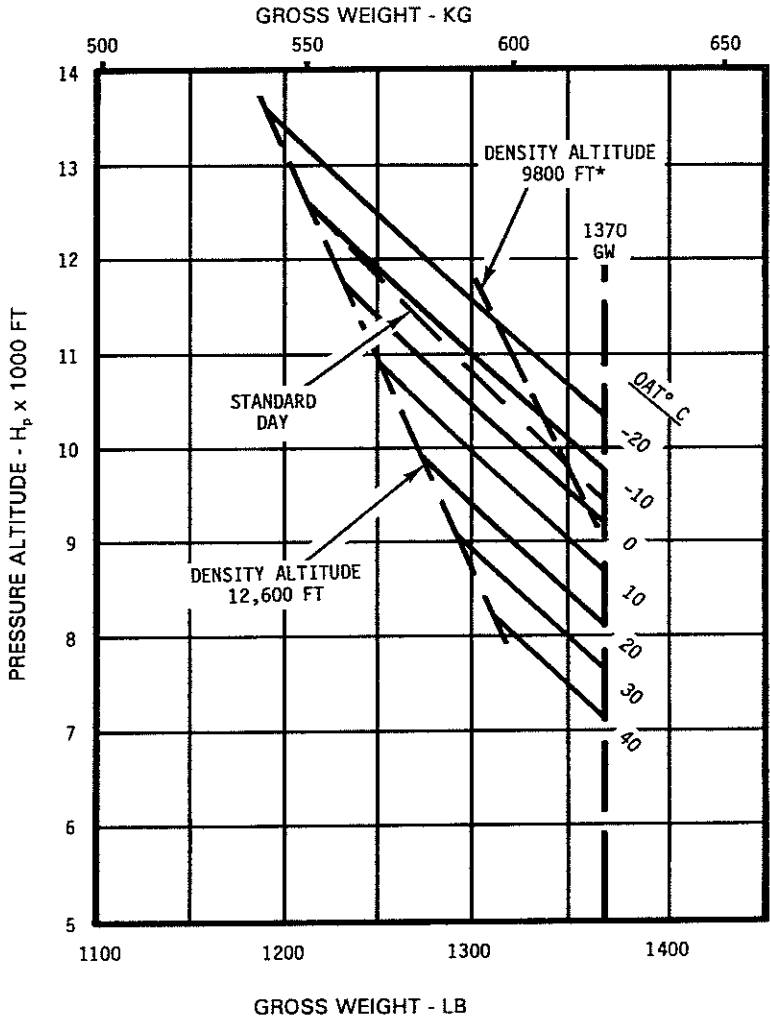

**R22 BETA II
O-360-J2A ENGINE**

IGE HOVER CEILING VS. GROSS WEIGHT

*Hover controllability with 17 knot wind substantiated up to 9800 feet density altitude.

OUT OF GROUND EFFECT, ZERO WIND
LIMIT MANIFOLD PRESSURE TO CRITICAL ALTITUDE
FULL THROTTLE ABOVE CRITICAL ALTITUDE
104% RPM

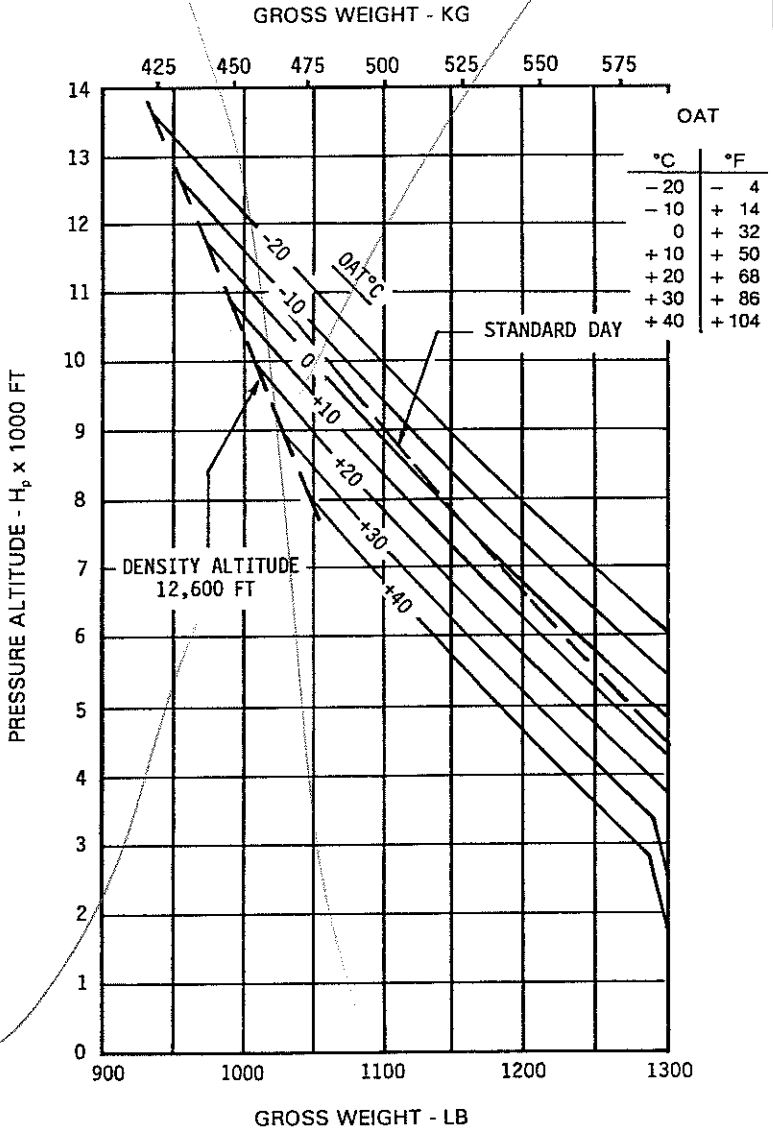

**R22 STANDARD
O-320-A2B OR A2C ENGINE
OGE HOVER CEILING VS. GROSS WEIGHT**

OUT OF GROUND EFFECT, ZERO WIND
LIMIT MANIFOLD PRESSURE TO CRITICAL ALTITUDE
FULL THROTTLE ABOVE CRITICAL ALTITUDE
104% RPM

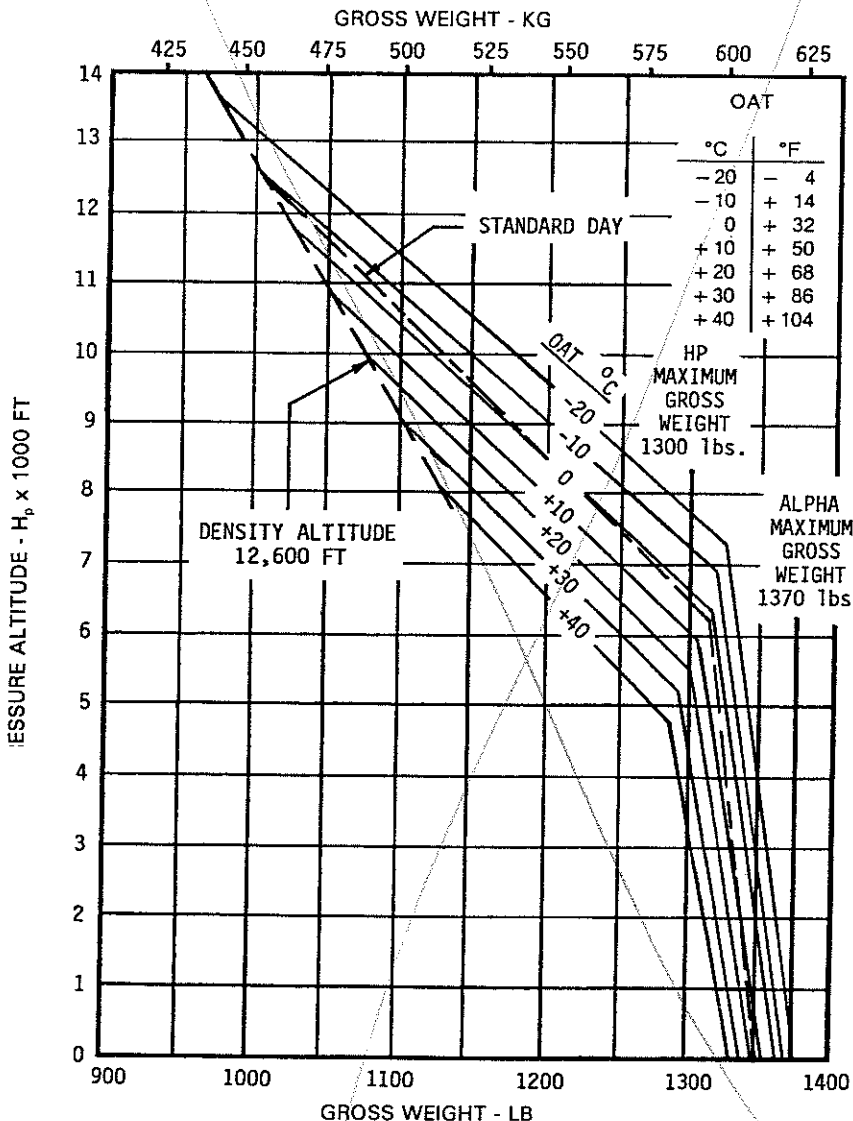

**R22 HP & ALPHA
O-320-B2C ENGINE**

OGE HOVER CEILING VS. GROSS WEIGHT

OUT OF GROUND EFFECT, ZERO WIND
TAKEOFF POWER OR FULL THROTTLE
104% RPM

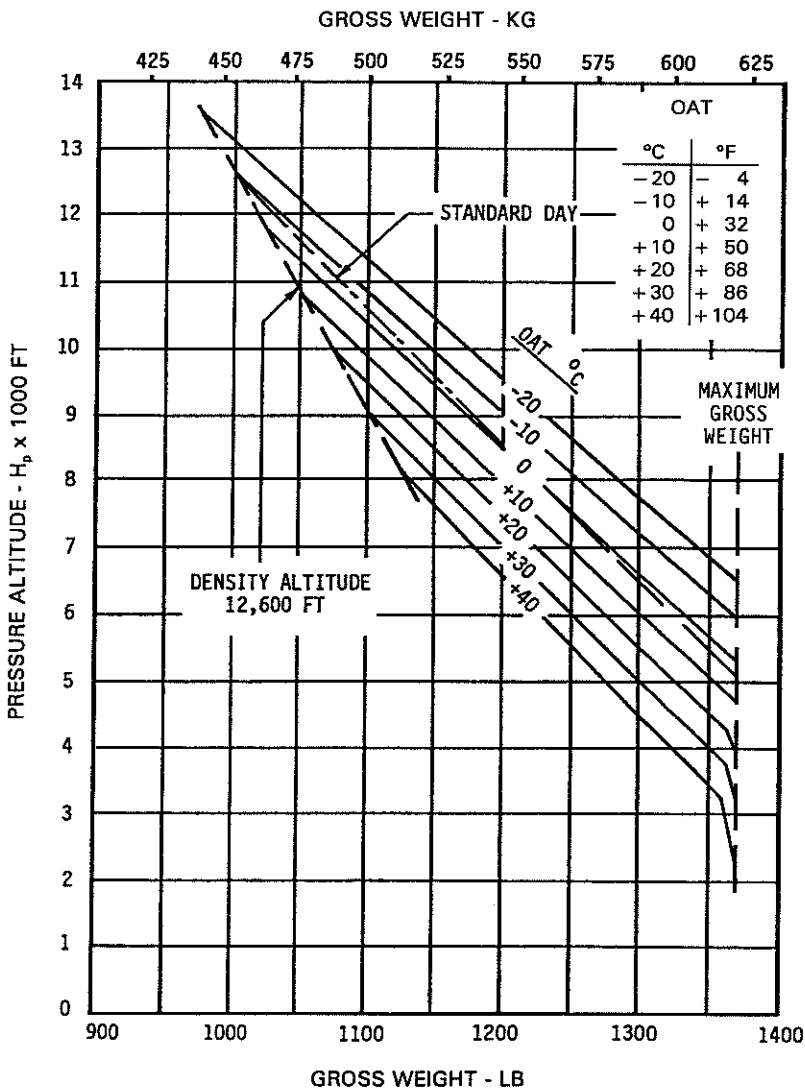

**R22 BETA
O-320-B2C ENGINE
OGE HOVER CEILING VS. GROSS WEIGHT**

OUT OF GROUND EFFECT, ZERO WIND
TAKEOFF POWER OR FULL THROTTLE
104% RPM

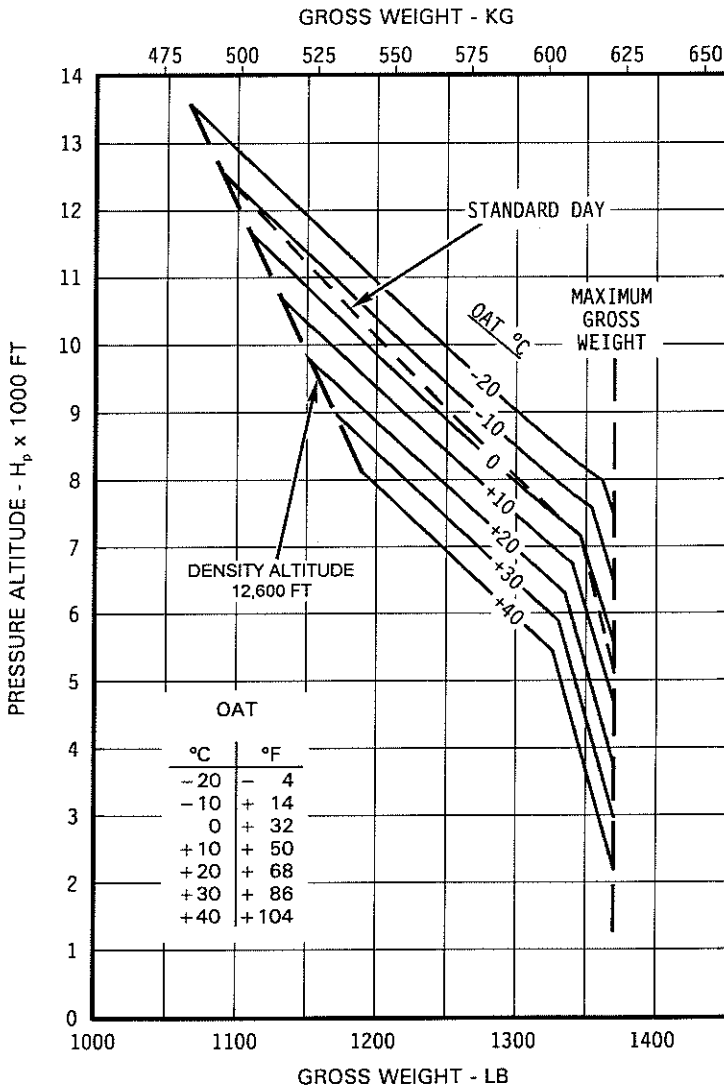

**R22 BETA II
O-360-J2A ENGINE**

OGE HOVER CEILING VS. GROSS WEIGHT

DEMONSTRATED CONDITIONS:
SMOOTH HARD SURFACE
WIND CALM
103-104% RPM

AVOID OPERATION IN SHADED AREAS

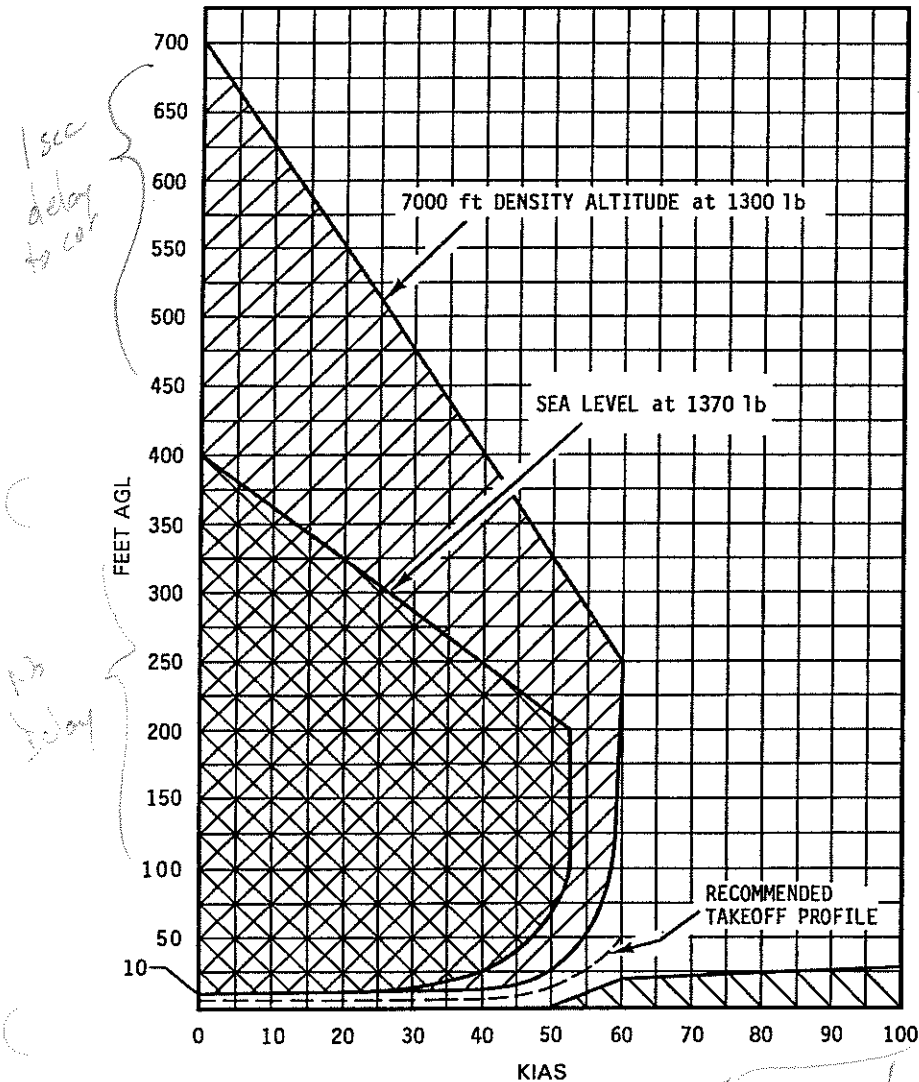

HEIGHT - VELOCITY DIAGRAM

THIS PAGE INTENTIONALLY LEFT BLANK.

SECTION 6
WEIGHT AND BALANCE
CONTENTS

	Page
General	6-1
Weight and Balance Record	6-1
Loading Instructions	6-3

INTENTIONALLY BLANK

SECTION 6

WEIGHT AND BALANCE

GENERAL

The helicopter must be flown only within weight and balance limits specified in Section 2. Loadings outside these limits can result in insufficient control travel for safe control. Refer to **LOADING INSTRUCTIONS** to ensure loading within safe limits.

CAUTION

Fuel is located aft of helicopter CG, causing CG to move forward during flight. Always determine safe loading with empty fuel as well as with takeoff fuel. Amount of fuel which can be off-loaded to allow for greater payload is limited by forward CG location with empty fuel.

WEIGHT AND BALANCE RECORD

An equipment list giving helicopter configuration, empty weight, and center of gravity is provided with each helicopter. This data applies to the helicopter as delivered from the factory. Any changes in helicopter configuration should be documented using the form on page 6-2.

CAUTION

Following any modification which moves empty CG aft, calculate weight and balance with full fuel and 130 lb pilot (135 lb pilot with aux tank). If calculation shows CG aft of aft limit, fixed ballast must be installed in nose to comply with minimum solo pilot weight limitation in Section 2.

LOADING INSTRUCTIONS

The following table may be used when determining loaded helicopter weight and CG position.

Item	Weight (lb)	Longitudinal CG, inches	Lat CG, inches (+ = right side)
Pilot and baggage under right seat		78.0*	+ 10.7
Passenger and baggage under left seat		78.0*	- 9.3
Main fuel		108.6	- 11.0
Aux fuel (optional)		103.8	+ 11.2
Doors	5.2 each	77.5	± 21.0
Removable Cyclic	0.8	68.0	- 8.0
Removable Collective	1.1	80.7	- 19.5
Removable Pedals (both pedals)	0.8	46.5	- 9.5

*Use 79.0 for aircraft prior to S/N 0256 with early-style seats. If backrest cushion is used, subtract thickness of compressed cushion.

LOADING INSTRUCTIONS (cont'd)

The following sample calculation demonstrates how to determine loaded helicopter weight and longitudinal center of gravity. These may then be compared with the CG limits given in Section 2 to determine safe loading. Alternately, total moments may be compared with the allowable moment charts on pages 6-6 and 6-7. Both takeoff and empty fuel conditions must be within limits.

It is usually not necessary to determine lateral CG position as most optional equipment is located near centerline. If an unusual installation or loading occurs, lateral CG should be checked against the CG limits given in Section 2. The lateral CG datum is the aircraft centerline with items to the right positive and items to the left negative.

LOADING INSTRUCTIONS (cont'd)

SAMPLE LOADING CALCULATION

Item	Arm (Inches from Datum)	Sample Helicopter		Your Helicopter	
		Weight (lb)	Moment (in-lb)	Weight (lb)	Moment (in-lb)
Basic empty weight as equipped (Includes unusable fuel and full oil)	104.0	850	88,400		
Remove pilot door	77.5	-5.2	-403		
Pilot, passenger, and baggage	78.0	342	26,676		
Total weight and balance with zero usable fuel	96.6	1187	114,673		
Usable main tank fuel at 6 lbs/gal.	108.6	115	12,489		
Usable aux tank fuel at 6 lbs/gal.	103.8	63	6,539		
Total weight and balance with take-off fuel	97.9	1365	133,701		

Note: CG location (arm) aft of datum for loaded helicopter is determined by dividing total weight into total moment.

LOADING INSTRUCTIONS (cont'd)

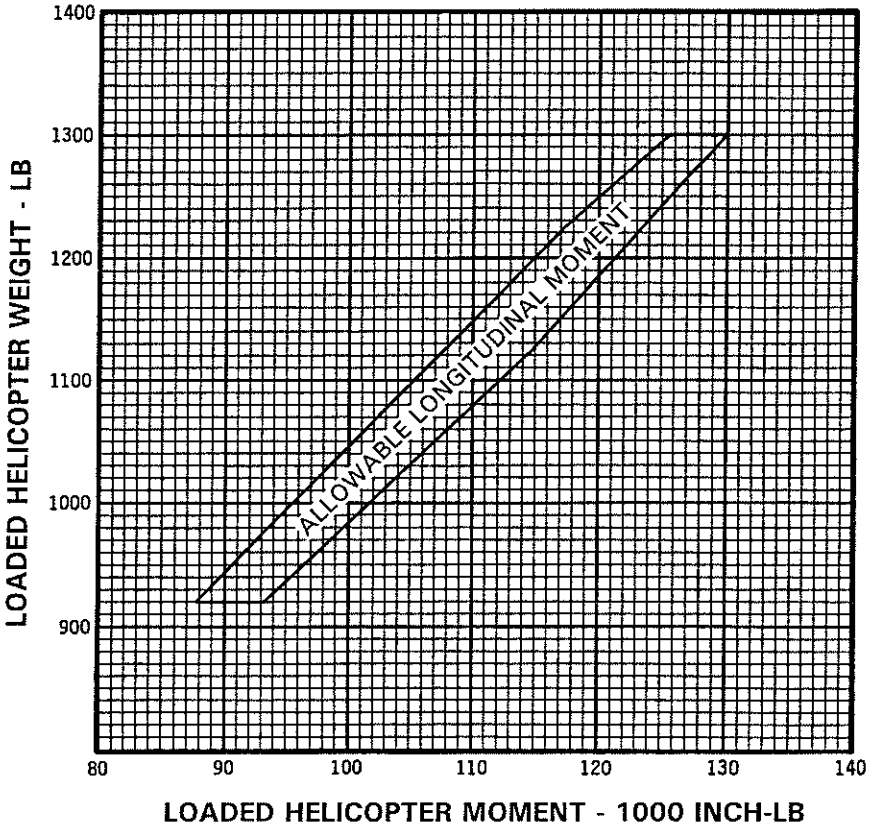

R22 STANDARD AND HP

ALLOWABLE LOADED MOMENT VS. GROSS WEIGHT
ENVELOPE

LOADING INSTRUCTIONS (cont'd)

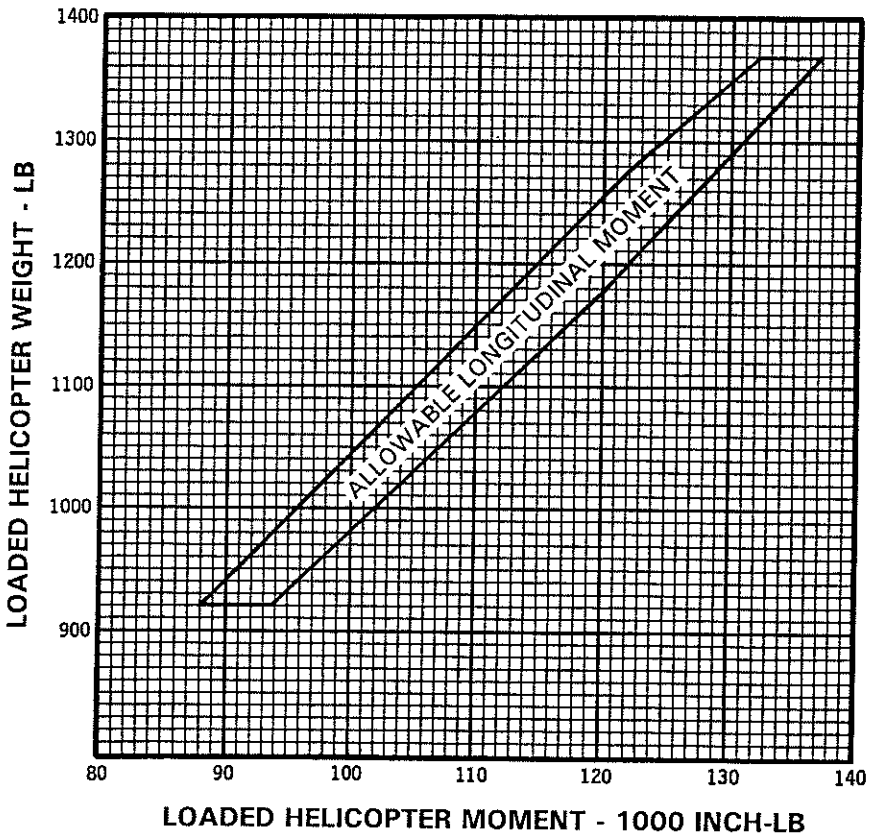

R22 ALPHA, BETA, AND BETA II

ALLOWABLE LOADED MOMENT VS. GROSS WEIGHT
ENVELOPE

THIS PAGE INTENTIONALLY LEFT BLANK.

SECTION 7
SYSTEMS DESCRIPTION

CONTENTS

	Page
Airframe	7-1
Rotor Systems	7-2
Drive System	7-2
Powerplant	7-3
Flight Controls	7-4
Removable Flight Controls	7-4.1
RPM Governor	7-4.2
Control Trim and Friction	7-5
Engine Controls	7-6
Clutch Actuator	7-7
Fuel System	7-7
Electrical System	7-8
Lighting System	7-12
Instrument Panel	7-13
Intercom System	7-16
Pitot-Static System	7-17
Tachometers	7-17
Warning Lights	7-18
Heating and Ventilation	7-19
Seats, Belts, and Baggage	7-20
Landing Gear	7-20
Rotor Brake	7-21
Engine Primer System (Optional)	7-21
Carbon Monoxide Detector	7-22
Emergency Locator Transmitter (Optional)	7-23

INTENTIONALLY BLANK

SECTION 7

SYSTEMS DESCRIPTION

AIRFRAME

The R22 is a two-place, single main rotor, single engine helicopter constructed primarily of metal and equipped with skid type landing gear.

The primary structure of the fuselage is welded steel tubing and riveted aluminum. The tailcone is a monocoque structure in which the aluminum skins carry the primary loads. Fiberglass and thermoplastics are used in the secondary structure of the cabin, engine cooling system and in various other ducts and fairings. The doors are also constructed of fiberglass and thermoplastics.

A cowl door on the right side provides access to the main rotor gearbox and drive system. For additional access to controls and other components, there are removable panels between the seat cushions and seat backs, on each side of the engine compartment, and under the cabin.

The instrument console hinges up and aft to provide access to the battery if it is mounted in the nose. Small removable plug buttons are located on the tailcone for internal inspection.

One stainless steel firewall is located forward and another above the engine compartment.

Both cabin doors may be removed and installed by maintenance personnel or pilots. To remove a door, remove cotter pins in upper and lower hinges, then open and lift door to disengage hinges. (Older doors may only have provisions for upper cotter pin.) To install, use reverse procedure. Adjust weight and balance as required when removing and installing doors.

ROTOR SYSTEMS

The main rotor has two all-metal blades mounted to the hub by coning hinges. The hub is mounted to the shaft by a teeter hinge. The coning and teeter hinges use self-lubricated bearings. Droop stops for the main rotor blades provide a teeter hinge friction restraint which normally prevents the rotor from teetering while stopping or starting. Pitch change bearings for each blade are enclosed in a housing at the blade root. The housing is filled with oil and sealed with a neoprene boot. Each blade has a thick stainless steel spar at the leading edge which is resistant to corrosion and erosion. Stainless steel skins are bonded to the spar approximately one inch aft of the leading edge. Blades must be refinished if the paint erodes to bare metal at the skin-to-spar bond line. Bond may be damaged if bond line is exposed.

The tail rotor has two all-metal blades and a teetering hub with a fixed coning angle. The pitch change bearings have self-lubricated liners. The teeter hinge bearings either have self-lubricated liners or are elastomeric. The tail rotor blades are constructed with aluminum skins and forged aluminum root fittings.

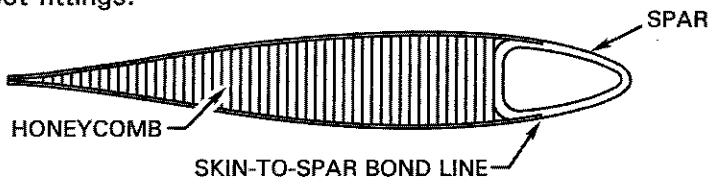

MAIN ROTOR BLADE CONSTRUCTION

DRIVE SYSTEM

A vee-belt sheave is bolted directly to the engine output shaft. Vee-belts transmit power to the upper sheave which has an overrunning clutch contained in its hub. The inner shaft of the clutch transmits power forward to the main rotor and aft to the tail rotor. Flexible couplings are located at the main gearbox input and at each end of the long tail rotor drive shaft.

The main gearbox contains a single-stage spiral-bevel gear set which is splash lubricated. A cooling duct under the box is connected to the top of the engine shroud. The main gearbox is supported by four rubber mounts.

DRIVE SYSTEM (cont'd)

The long tail rotor drive shaft has no hanger bearings but has a lightly-loaded damper bearing. The tail gearbox contains a splash-lubricated spiral-bevel gear set. The tail gearbox output shaft is stainless steel to resist corrosion.

POWERPLANT

One Lycoming four-cylinder, horizontally-opposed, overhead-valve, air-cooled, carbureted engine with a wet sump oil system powers the helicopter. The engine is equipped with a starter, alternator, shielded ignition, two magnetos, muffler, oil cooler, and induction air filter. See Sections 1 and 2 for powerplant specifications and limitations.

A direct-drive, squirrel-cage fan mounted to the engine output shaft supplies cooling air to the cylinders and oil cooler via a fiberglass and aluminum shroud. Ducts from the shroud supply cooling air to the alternator and main rotor gearbox.

Induction air enters through an inlet on the right side of the aircraft and passes through a flexible duct to the carburetor air box. A hot air scoop supplies heated air to the air box. A sliding valve controlled by the pilot allows either cool or warm air to flow into the box, through the air filter, and up into the carburetor.

The pilot should read and adhere to procedures recommended in the Lycoming Operator's Manual to obtain maximum engine life and efficiency.

FLIGHT CONTROLS

Dual controls are standard equipment and all primary controls are actuated through push-pull tubes and bellcranks. Bearings used throughout the control system are either sealed ball bearings or have self-lubricated Teflon liners.

Flight controls are conventional. The cyclic stick appears to be different but the grip moves the same as in other helicopters due to the free hinge at the center pivot. The cyclic grip is free to move vertically, allowing the pilot to rest his forearm on his knee if he chooses.

The collective stick is also conventional with a twist grip throttle control. When the collective is raised, the throttle is opened by an interconnecting linkage. An electronic governor makes minor throttle adjustments required to maintain RPM.

CAUTION

Above 4000 feet, throttle correlation and governor are less effective. Therefore, power changes should be slow and smooth.

CAUTION

At high power settings above 4000 feet, the throttle is frequently wide open and RPM must be controlled with collective.

REMOVABLE FLIGHT CONTROLS

Removable left-seat flight controls are optional on the R22. These controls may be removed and installed by maintenance personnel or pilots as follows:

1. To remove cyclic, extract quick release pin by depressing button and pulling, then pull outward on left grip while supporting stick. To install, use reverse procedure.

CAUTION

After removing cyclic control, place protective plastic cap on exposed cyclic tube to prevent possible injury.

2. To remove collective, push boot aft to expose spring clip or locking pins. Either spread spring clip or depress locking pins and pull forward on stick. To install, be sure placards are face up, then use reverse procedure. It may be necessary to rotate stick slightly to allow pins to snap into place.

CAUTION

When collective control is installed, ensure both ends of locking clip or both locking pins are fully engaged through holes on each side.

3. To remove tail rotor pedals, depress locking pin while twisting pedal counterclockwise, then pull up. To install, use reverse procedure.

RPM GOVERNOR

The governor maintains engine RPM by sensing changes and applying corrective throttle inputs through a friction clutch which can be easily overridden by the pilot. The governor is only active above 80% engine RPM and can be switched on or off using the toggle switch on the end of the right seat collective.

The governor is designed to assist in controlling RPM under normal conditions. It may not prevent over- or under-speed conditions generated by aggressive flight maneuvers.

CAUTION

When operating at high density altitudes, governor response rate may be too slow to prevent overspeed during gusts, pull-ups, or when lowering collective.

CONTROL TRIM AND FRICTION

Balancing trim springs are incorporated in the cyclic and collective controls. The collective-up spring balances the rotor loads, allowing the pilot to remove his left hand from the collective during most flight regimes. The longitudinal cyclic has a fixed bungee spring which cancels most longitudinal stick forces during cruise flight.

The lateral cyclic is equipped with an on-off trim spring to cancel the left stick force which occurs during high speed flight. The spring is actuated by a push-pull knob located just forward of the cyclic stick. For S/N 550 and subsequent, fine adjustment of the trim force is controlled by the knob located on the left side of the console.

CAUTION

If mixture control is inadvertently pulled in flight, engine stoppage will result. To avoid pulling wrong control, always reach around left side of cyclic to actuate lateral trim.

The cyclic and collective controls are equipped with adjustable friction devices. A toggle type lever is located near the aft end of the center collective stick. It is actuated aft to increase friction and forward to release it.

The cyclic friction knob is located to the left of the cyclic stick. Turning the knob clockwise applies friction to both the longitudinal and lateral cyclic. Cyclic friction is normally applied only on the ground.

The pedals actuate push-pull controls connected directly to the tail rotor pitch control and do not incorporate any trim spring or friction devices.

CAUTION

Control friction must be used with caution if applied during flight to avoid inadvertent locking of a control.

ENGINE CONTROLS

A twist-grip throttle control is located on each collective stick. They are interconnected and actuate the butterfly valve on the carburetor through a system of bellcranks and push-pull tubes.

The linkage is designed so that the throttle will open as the collective stick is raised. A detent spring, located in the vertical throttle push-pull tube, allows the pilot to roll his throttle off beyond the idle stop prior to a ground contact (run-on) autorotation landing. This prevents the throttle correlation from adding power when the collective stick is raised.

Correct throttle linkage adjustment may be verified during preflight by rolling the twist-grip through the detent spring and holding against the hard idle stop. The butterfly on the carburetor should just barely start to move when the collective is raised to the full-up position.

Other engine controls include a mixture control located forward and to the right of the cyclic stick and a carburetor heat control located to the right and aft of the cyclic. R22s with O-360 engines are equipped with Carb Heat Assist which is described in section 4.

CAUTION

If mixture control is leaned at high altitude, be sure it is pushed back in before descending to lower altitude, otherwise engine may quit. If engine stops, lower collective, push mixture to full rich, and restart. DO NOT disengage clutch.

NOTE

On some aircraft, the mixture control is located on the console face. The mixture guard is not used with this mixture control.

CLUTCH ACTUATOR

After the engine is started, it is coupled to the rotor drive system through vee-belts which are tensioned by raising the upper drive sheave. An electric actuator, located between the drive sheaves, raises the upper sheave when the pilot engages the clutch switch. The actuator senses compressive load (belt tension) and switches off when the vee-belts are properly tensioned. A caution light illuminates whenever the actuator is operating, either engaging, disengaging, or retensioning the belts. The light stays on until the belts are properly tensioned or completely disengaged.

A fuse located on or near the test switch panel prevents an actuator motor overload from tripping the circuit breaker and turning off the caution light prematurely.

CAUTION

Never take off while clutch caution light is on.

FUEL SYSTEM

The fuel system is gravity-flow (no fuel pumps) and includes a fuel tank, a shut-off valve in the cabin behind the left seat, and a strainer (gascolator). The tank air vent is located inside the mast fairing.

A drain is located at the forward left side of the tank and is opened by pushing in on the extended tube. A drain is also provided on the gascolator located on the lower left side of the vertical firewall. Both drains should be opened daily prior to flight to check for water, sediment, and fuel type/grade.

The fuel gage is electrically operated by a float-type transmitter in the tank. When the gage reads E, the tank is empty except for a small quantity of unusable fuel. The low-fuel warning light is actuated by a separate electric sender located on the bottom of the tank.

The optional auxiliary tank is interconnected with the main tank so one valve controls the flow from both tanks. The aux tank has a separate air vent, fuel quantity indicator, and sump drain.

ELECTRICAL SYSTEM

The electrical system includes a 14 volt, 60 ampere alternator, voltage controller, battery relay, and a 12 volt battery. The voltage controller is located on the right side of the vertical firewall. The battery is located either in the left side of the engine compartment or beneath the instrument console.

Various switches are located on the console and the circuit breakers are on the ledge just forward of the left seat. Breakers are marked to indicate function and amperage and are of the push-to-reset type. If a circuit breaker trips, wait a few seconds for it to cool before resetting.

ELECTRICAL SYSTEM (cont'd)

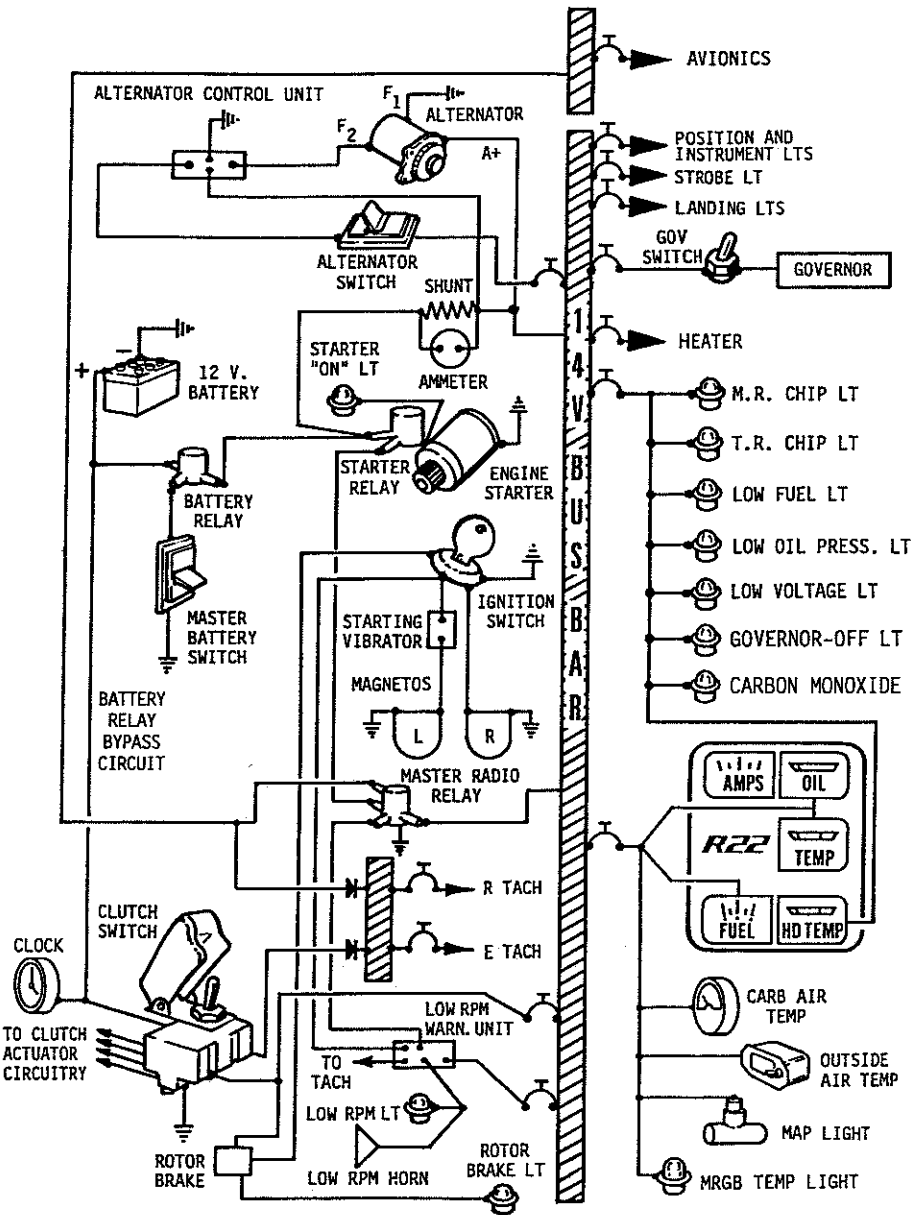

**ELECTRICAL SYSTEM
ALPHA, BETA, & BETA II**

ELECTRICAL SYSTEM (cont'd)

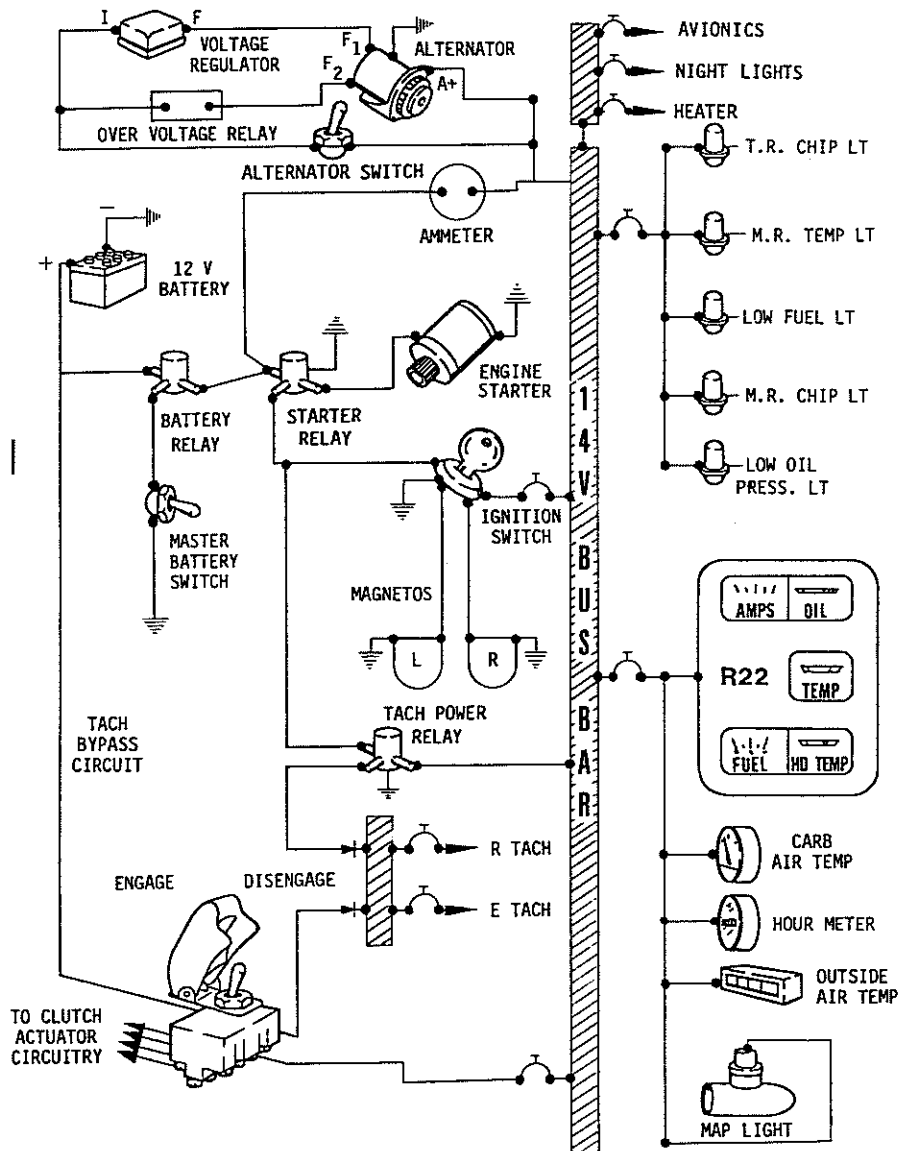

**ELECTRICAL SYSTEM
R22 STANDARD & HP**

ELECTRICAL SYSTEM (cont'd)

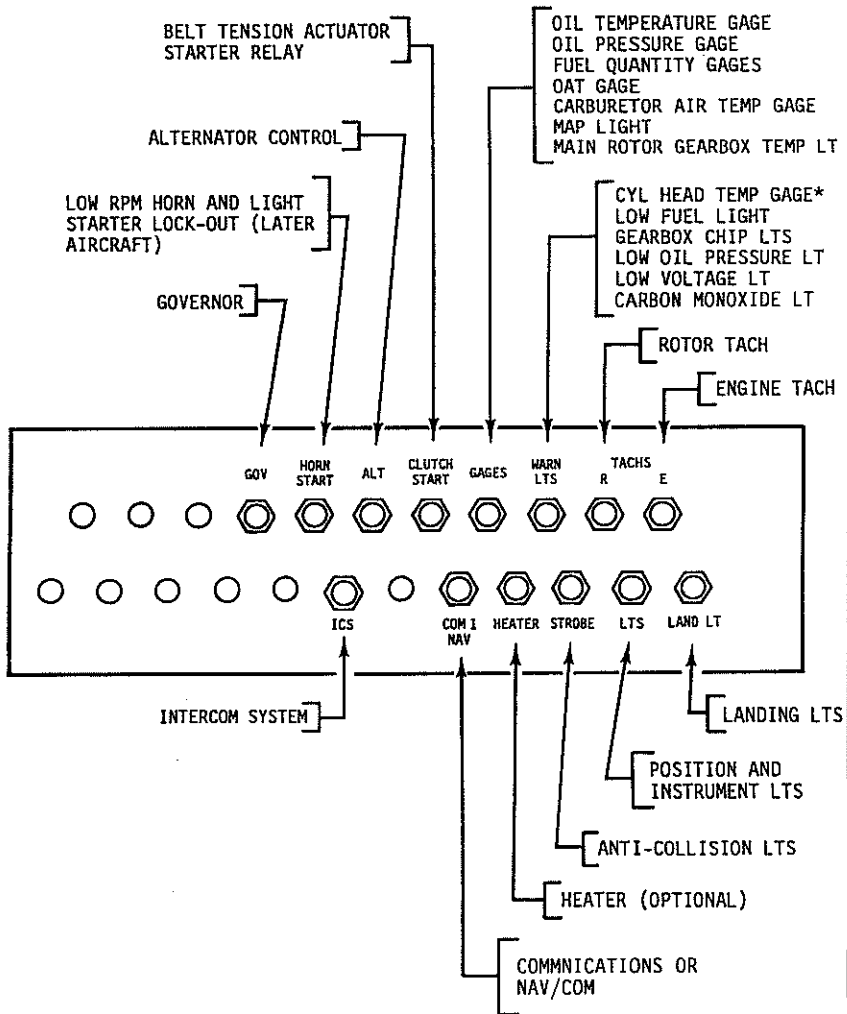

*ON GAGES CIRCUIT BREAKER PRIOR TO SHIP S/N 656.

CIRCUIT BREAKER PANEL - TYPICAL

(Exact panel configuration may vary with optional equipment and date of helicopter manufacture)

ELECTRICAL SYSTEM (cont'd)

The MASTER BATTERY switch controls the battery relay which disconnects the battery from the electrical system. A small power wire bypasses the battery relay to allow the tachometers and the clock to continue to receive battery power with the MASTER BATTERY switch off.

The alternator control unit protects the electrical system from overvoltage conditions. The ammeter indicates current to the battery ("—" indicates discharge). If ALT light comes on or ammeter indicates discharge during flight, turn off all nonessential electrical equipment and switch ALT off and back on after one second to reset. If ALT light stays on or ammeter still indicates discharge, terminate flight as soon as practical.

CAUTION

Continued flight with malfunctioning charging system can result in loss of power to electronic tachometers, producing a hazardous flight condition.

LIGHTING SYSTEM

An anti-collision strobe light is installed on the tailboom. Night lights include navigation lights on each side of the cabin and on the tail. Twin landing lights are installed in the nose at different vertical angles to increase the pilot's field of vision. Post and internal lights illuminate the instruments. An overhead map light provides additional and emergency lighting. The map light switch is located at the base of the light. A dimmer control for panel lights is located above the NAV LTS switch. Panel lights function only when the NAV LTS switch is on.

LIGHTING SYSTEM (cont'd)

The strobe, navigation and landing lights each have separate circuit breakers. The panel lights are on the same breaker as the navigation lights but the map light is on a breaker with the panel gages.

The landing light switch is located on the console face above the avionics or on the cyclic center post.

CAUTION

The location of the landing light switch should be carefully memorized so it can be turned on without delay in an emergency.

NOTE

Landing lights operate only when CLUTCH switch is in engage position.

INSTRUMENT PANEL

Standard flight instruments include a rate of climb indicator, airspeed indicator, engine and rotor dual tachometer, sensitive altimeter, manifold pressure gage, and magnetic compass. The engine cluster gages include an ammeter, oil pressure, oil temperature, cylinder head temperature, and fuel quantity for main and aux (if installed) tanks. Also provided are a clock, carburetor air temperature gage, and digital outside air temperature gage. Space on the panel is also provided for optional instruments and avionics. An hourmeter actuated by engine oil pressure is located forward of the pilot's seat.

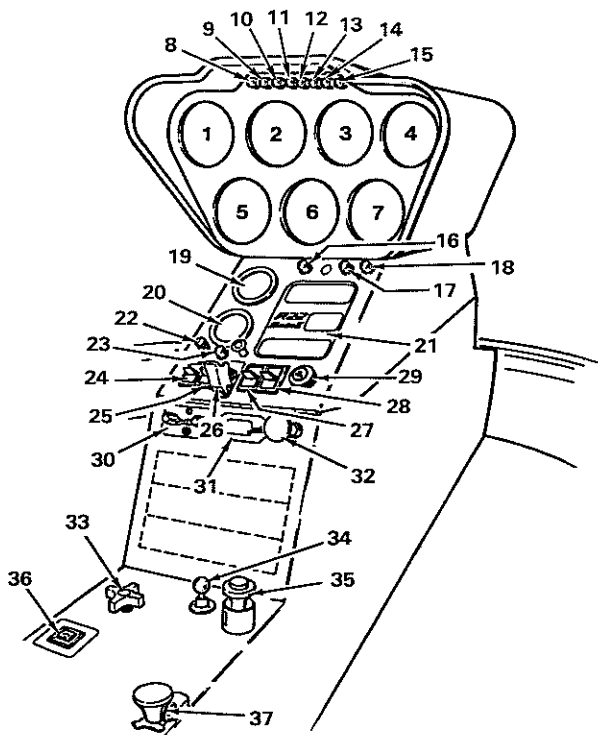

- | | |
|-----------------------------|------------------------------|
| 1. VERT SPEED INDICATOR | 20. CARB AIR TEMP OR CLOCK |
| 2. OPTIONAL INSTRUMENT | 21. ENGINE INSTRUMENTS |
| 3. AIRSPEED INDICATOR | 22. PANEL LIGHTS DIMMER |
| 4. ENGINE & ROTOR TACH | 23. ROTOR BRAKE LIGHT |
| 5. ALTIMETER | 24. NAVIGATION LIGHTS SWITCH |
| 6. OPTIONAL INSTRUMENT | 25. STROBE LIGHT SWITCH |
| 7. MANIFOLD PRESSURE | 26. CLUTCH ACTUATOR SWITCH |
| 8. CLUTCH LIGHT | 27. ALTERNATOR SWITCH |
| 9. M.R. GEARBOX TEMP LIGHT | 28. MASTER BATTERY SWITCH |
| 10. M.R. GEARBOX CHIP LIGHT | 29. IGNITION SWITCH |
| 11. CARBON MONOXIDE LIGHT | 30. INTERCOM |
| 12. STARTER-ON LIGHT | 31. OUTSIDE AIR TEMP |
| 13. T.R. GEARBOX CHIP LIGHT | 32. CABIN AIR |
| 14. LOW FUEL LIGHT | 33. CYCLIC FRICTION |
| 15. LOW RPM LIGHT | 34. CYCLIC RIGHT TRIM |
| 16. ALT LOW VOLTAGE LIGHT | 35. MIXTURE CONTROL |
| 17. OIL PRESSURE LIGHT | 36. ELT SWITCH (OPTIONAL) |
| 18. GOVERNOR-OFF LIGHT | 37. CARB HEAT |
| 19. CLOCK OR CARB AIR TEMP | |

INSTRUMENT PANEL - TYPICAL

(Exact panel configuration may vary with optional equipment and date of helicopter manufacture.)

ELECTRICAL SYSTEM (cont'd)

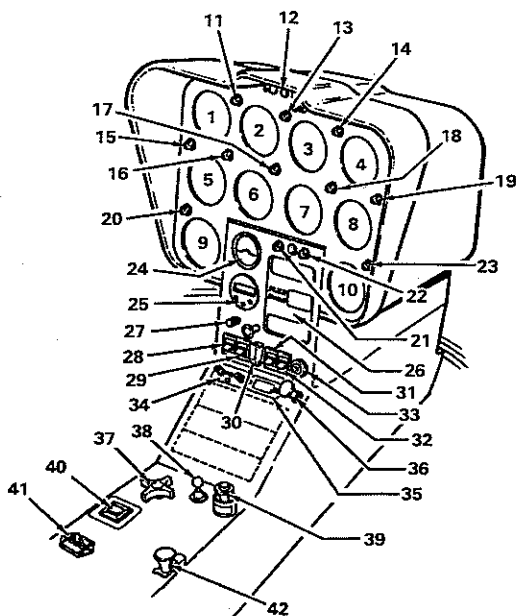

- | | |
|-----------------------------|------------------------------|
| 1. ENGINE & ROTOR TACH | 22. OIL PRESSURE LIGHT |
| 2. AIR SPEED INDICATOR | 23. ROTOR BRAKE LIGHT |
| 3. ARTIFICIAL HORIZON | 24. CARBURETOR AIR TEMP |
| 4. ALTIMETER | 25. CHRONOMETER |
| 5. MANIFOLD PRESSURE | 26. ENGINE INSTRUMENTS |
| 6. TURN COORDINATOR | 27. PANEL LIGHTS DIMMER |
| 7. HSI | 28. NAVIGATION LIGHTS SWITCH |
| 8. VERT SPEED INDICATOR | 29. STROBE LIGHT SWITCH |
| 9. OPTIONAL INSTRUMENT | 30. CLUTCH ACTUATOR SWITCH |
| 10. OPTIONAL INSTRUMENT | 31. ALTERNATOR SWITCH |
| 11. M.R. GEARBOX TEMP LIGHT | 32. MASTER BATTERY SWITCH |
| 12. MARKER BEACON | 33. IGNITION SWITCH |
| 13. T.R. GEARBOX CHIP LIGHT | 34. INTERCOM |
| 14. M.R. GEARBOX CHIP LIGHT | 35. OUTSIDE AIR TEMP |
| 15. STARTER-ON LIGHT | 36. CABIN AIR |
| 16. LOW RPM LIGHT | 37. CYCLIC FRICTION |
| 17. LOW FUEL LIGHT | 38. CYCLIC RIGHT TRIM |
| 18. CARBON MONOXIDE LIGHT | 39. MIXTURE CONTROL |
| 19. CLUTCH LIGHT | 40. ELT SWITCH (OPTIONAL) |
| 20. GOVERNOR-OFF LIGHT | 41. SLAVE CONTROL |
| 21. ALT LOW VOLTAGE LIGHT | 42. CARB HEAT |

OPTIONAL INSTRUMENT PANEL

(Exact panel configuration may vary with optional equipment and date of helicopter manufacture.)

INTERCOM SYSTEM

Earlier R22s are equipped with an intercom system that operates in either push-to-talk (PTT) or hot mic modes. A toggle switch to the left of the base of the cyclic stick is used to change modes. In PTT mode, the intercom is activated using the INTCM buttons located at the cyclic grips. An additional foot-activated intercom button is located on the left-hand forward floor. The pilot and co-pilot may transmit by keying the XMIT buttons located at the cyclic grips.

Later R22s are equipped with a voice-activated intercom system. The ICS VOLUME knob controls intercom volume but does not affect radio volume. The VOX SQUELCH knob is used to set the threshold volume at which the intercom is activated. When the knob is turned fully counter-clockwise to the LIVE position, the intercom is constantly on. When the knob is turned fully clockwise, keying one of the intercom buttons is required to activate the intercom. An amber indicator light illuminates when the intercom is active, and a green indicator light illuminates during transmission.

Later R22s may also be equipped with trigger-style intercom/ transmit switches at the cyclic grips. The first detent of the trigger switch activates the intercom and the second detent transmits.

PITOT-STATIC SYSTEM

The pitot-static system supplies air pressure to operate the airspeed indicator, altimeter, and vertical speed indicator. The pitot tube is located on the front edge of the mast fairing. The static source is located inside the aft cowling inboard of the cowl door hinge.

Water can be drained from the pitot-static lines by removing the plastic drain plugs which are accessible through the inspection panel on the underside of the cabin. Draining lines should only be required if the airspeed indicator or altimeter appears erratic.

Pitot and static sources should be inspected frequently for bugs or other obstructions.

TACHOMETERS

An electronic engine and rotor dual tachometer is standard. Engine tachometer signal is provided by magneto breaker points. Rotor tachometer signal is provided by two magnets on the main gearbox drive yoke. Each tachometer circuit has a separate circuit breaker and is completely independent from the other. With MASTER BATTERY and ALT switches off, the tachometer bus continues to receive power from the battery through a bypass circuit as long as the CLUTCH switch is in the engage position.

CAUTION

Installation of electrical devices can affect accuracy and reliability of electronic tachometers, low RPM warning system, and governor. Therefore, no electrical equipment may be installed unless specifically approved by the factory.

WARNING LIGHTS

Warning lights include clutch, main gearbox over-temperature, main and tail gearbox chip, starter on (later aircraft), low fuel, low RPM, alternator, low oil pressure, and rotor brake. The clutch light indicates that the actuator is tightening the vee belts. The low RPM light and horn indicate rotor RPM at 97% or below. The low oil pressure and low fuel lights are actuated by sensors in those systems and are independent of gage indicators. The alternator light warns of a possible alternator failure. The governor-off light, if installed, indicates governor is switched off.

The main and tail gearbox chip detectors are magnetic devices located in the drain plug of each gearbox. When metallic particles are drawn to the magnets they close an electrical circuit, illuminating the warning light. The metal particles may be caused by a failing bearing or gear, thus giving the pilot warning of impending gearbox failure. The main gearbox over-temp light is actuated by a temperature switch located near the input pinion bearing.

The carbon monoxide light, if installed, is activated by a sensor above the pilot's heater outlet and indicates elevated cabin carbon monoxide levels.

HEATING AND VENTILATION

Fresh air vents are located in each door and in the nose. Door vents are opened and closed using the center pivot of the double arm linkage. Pushing in on the pivot will seal and lock the door vents closed. For maximum ventilation, open door vents wide during hover, but only one inch or less during cruise. A stop is provided to hold vents partially open.

The fresh air inlet in the nose is opened by pulling the cabin air knob on the console face. Air from the nose inlet is directed along inside surface of windshield for defogging as well as for ventilation.

A cabin heater is available as optional equipment. It consists of an electric blower on the left side of the engine compartment, a muffler heat shroud, a control valve at the firewall, an outlet grille forward of the pilot's seat or tail rotor pedals, and interconnecting ducts between components. The blower switch and valve control are located on the ledge forward of the pilot's seat. The switch turns the blower on and the push-pull control actuates the valve which directs heat either into the cabin or out an overboard discharge on the cabin underside.

NOTE

To prolong muffler life, have the heater shroud removed during warm seasons when heater will not be used.

CAUTION

When not in use or in case of engine fire, heat control should be in closed position to seal cabin area from engine compartment.

SEATS, BELTS, AND BAGGAGE

A baggage compartment is located under each seat. Seat cushions hinge forward for access. Each seat is equipped with a combined seat belt and inertia reel shoulder strap. The inertia reel is normally free but will lock if there is sudden movement as would occur in an accident.

The seats are not adjustable but each helicopter is supplied with a foam cushion which can be placed behind the pilot to position him forward. This allows most shorter pilots to reach the pedals, the cyclic stick in its most forward position, and controls on the center console.

LANDING GEAR

A spring and yield skid type landing gear is used. Most hard landings will be absorbed elastically. However, in an extremely hard landing, the struts will hinge up and outward as the center crosstube yields (takes permanent set) to absorb the impact. Very slight crosstube yielding is acceptable. However, yielding which allows the tail skid to be within 36 inches (24 inches for R22 Standard or HP) of the ground when the ship is sitting empty on level pavement requires crosstube replacement.

Hardened steel wear shoes are mounted on the bottom of the skids. These shoes should be inspected periodically, particularly if autorotation landings with ground contact have been performed. Replace shoes whenever the thinnest point is less than 1/16 of an inch (.06 in.).

ROTOR BRAKE

When installed, the rotor brake is mounted on the aft end of the main gearbox and actuated by a cable connected to a pull handle located above and behind the pilot's left shoulder. To stop the rotor, use the following procedure:

1. After pulling idle cutoff, wait at least 30 seconds.
2. Pull brake handle forward and down using moderate force (10 lb).
3. After rotor stops, release handle or, if use as parking brake is desired, hook bead chain in slot in bracket.

Brake must be released before starting engine. When the brake is engaged, a switch disconnects the starter to prevent the engine from being started.

CAUTION

Applying rotor brake without waiting at least 30 seconds after engine stops or using a force which stops the rotor in less than 20 seconds may permanently damage brake shoes.

ENGINE PRIMER SYSTEM (OPTIONAL)

The primer is used to improve cold starting of the engine. The primer pump is located in front of the right seat near the hourmeter. Engine priming is performed as follows:

1. Unlock pump by rotating the handle until the locking pin disengages and the handle pops up.
2. Pump handle as required for priming (normally two to three strokes).
3. Lock handle by aligning the locking pin and slot, then push down on handle and rotate approximately 180°.

CARBON MONOXIDE DETECTOR

The carbon monoxide (CO) detector, if installed, indicates elevated cabin CO levels. CO is an odorless, toxic gas present in engine exhaust which causes headaches, drowsiness, and possible unconsciousness. CO levels may become elevated due to an exhaust leak or possibly due to exhaust recirculation during prolonged hovering.

The CO detector system consists of a sensor above the pilot's heater outlet and a warning light. A system check (light flashes twice) is performed each time power is switched on. A sensor malfunction is indicated by a continuing flash every four seconds.

If the warning light illuminates, open nose and door vents and shut off heater as required to ventilate the cabin. If hovering, land or transition to forward flight. If symptoms of CO poisoning (headache, drowsiness, dizziness) accompany warning light, land immediately. Inspect exhaust system before next flight.

Many chemicals can damage the CO sensor. Avoid use of solvents, detergents, or aerosol sprays near the sensor. Tape off openings in top and bottom of sensor housing when cleaning cabin interior.

EMERGENCY LOCATOR TRANSMITTER (OPTIONAL)

The Emergency Locator Transmitter (ELT) installation consists of a transmitter with internal battery pack, an external antenna, and a remote switch/annunciator. The transmitter is mounted to the upper steel tube frame and is accessible through the aft cowl door. The remote switch/annunciator is located left of the cyclic stick.

The ELT is operated by a switch on the transmitter and by the remote switch. The transmitter switch has been secured in the AUTO position at installation and should always be in this position for flight. The remote switch/annunciator is a three position rocker switch with internal indicator light. This switch should also be in the AUTO (middle) position for flight. With both switches set to AUTO, the ELT will begin transmitting on international distress frequencies 121.5 and 243.0 MHz when subjected to a high "G" load. When the unit is transmitting, the red indicator in the rocker switch illuminates.

Moving the rocker switch to ON activates the transmitter for test or emergency situations. Use the ON position if an emergency landing is imminent and time permits.

If ELT is inadvertently activated, use the RESET position of the rocker switch to stop transmission and reset the unit. The red indicator will extinguish when unit is reset.

NOTE

Earlier aircraft may have ELT installations without remote switch.

For more detailed instructions on ELT operation, maintenance, and required tests, refer to manufacturer's instructions supplied with the unit.

THIS PAGE INTENTIONALLY LEFT BLANK.

SECTION 8
HANDLING AND MAINTENANCE

CONTENTS

	Page
General	8-1
Required Documents	8-1
Required Inspections	8-2
Preventive Maintenance By the Pilot	8-3
Alterations to Aircraft	8-4
Ground Handling	8-5
Parking	8-6
Engine Oil	8-6
Tail Rotor Gearbox Oil	8-8
Fuel	8-8
Battery	8-9
Cleaning Helicopter	8-10

INTENTIONALLY BLANK

SECTION 8

HANDLING AND MAINTENANCE

GENERAL

This section outlines procedures recommended for handling, servicing, and maintaining the R22 helicopter. Every owner should stay in close contact with a Robinson Service Center to obtain the latest service and maintenance information. Owners should also be registered with the factory to receive service bulletins, changes to this handbook, and other helpful information as it becomes available.

Federal Aviation Regulations place responsibility for maintenance of a helicopter on the owner and operator. He must insure that all maintenance is performed by qualified mechanics and in accordance with the R22 Maintenance Manual (Instructions for Continued Airworthiness), Service Bulletins/Service Letters, and FAA Airworthiness Directives.

All limits, procedures, safety practices, time limits, servicing, and maintenance requirements contained in this handbook are considered mandatory.

Authorized Robinson Service Centers will have recommended modification, service, and operating procedures issued by the FAA and by Robinson Helicopter Company. This available information will be useful in obtaining maximum utility and safety with the helicopter.

REQUIRED DOCUMENTS

The Airworthiness Certificate (FAA Form 8100-2) must be displayed in the aircraft at all times. The following additional documents must be carried in the aircraft:

1. Registration Certificate (FAA Form 8050-3)
2. Pilot's Operating Handbook

REQUIRED DOCUMENTS (cont'd)

The following documents should not be carried in the aircraft, but must be available for use by any mechanic or pilot servicing the aircraft:

1. Aircraft Logbook
2. Engine Logbook

NOTE

Required documents may vary in countries other than the United States.

REQUIRED INSPECTIONS

Federal Aviation Regulations require that all civil aircraft of U.S. registry undergo a complete (annual) inspection every twelve months. This annual inspection must be signed off by a mechanic with Inspection Authorization (IA). This inspection is required whether the helicopter is used commercially or privately.

In addition to the annual inspection, the R22 Maintenance Manual requires a complete inspection after every 100 hours of operation. The helicopter also incorporates a number of fatigue life-limited components which must be retired at specified time intervals. A list of these components is contained in the Airworthiness Limitations section of the R22 Maintenance Manual and Instructions for Continued Airworthiness.

The R22 helicopter design includes many unique features. Even with the help of a maintenance manual, an Airframe & Powerplant (A & P) mechanic is not qualified to perform the above inspections of the R22 helicopter without additional training. Therefore, these inspections must only be performed by properly rated personnel who have successfully completed a factory-approved maintenance course of instruction on the R22 helicopter.

REQUIRED INSPECTIONS (cont'd)

The factory occasionally publishes Service Bulletins and the Federal Aviation Administration (FAA) occasionally publishes Airworthiness Directives (ADs) that apply to specific groups of aircraft. They are mandatory changes or inspections which must be complied with within the time limit specified. Owners should periodically check with Robinson Service Centers to be sure that the latest Service Bulletins and ADs issued have been complied with.

PREVENTIVE MAINTENANCE BY THE PILOT

Part 43 of the Federal Aviation Regulations (FAR) allows a certified pilot who owns or operates an aircraft to obtain a maintenance manual and perform certain limited maintenance functions. These functions are defined in the above regulations, and, as they apply to the R22 helicopter, generally include the following:

1. Replace defective safety wire or cotter pins.
2. Replace bulbs, reflectors, and lenses of position and landing lights.
3. Replace, clean, or gap spark plugs.
4. Replace engine air filter.
5. Clean or refinish exterior of aircraft.
6. Replace wear shoes on landing gear skids.
7. Service or replace battery.
8. Change engine oil and filter.
9. Inspect chip detectors and add oil to tail rotor gearbox.
10. Remove or replace any cowling or inspection panels.
11. Remove and replace gascolator bowl.

Although the above work is allowed by law, it should only be performed by pilots confident that they are qualified to reliably complete the work. All work must be done in accordance with the maintenance manual.

PREVENTIVE MAINTENANCE BY THE PILOT (cont'd)

After completing the work, when required, the pilot must enter the following in the appropriate logbook:

1. Date work accomplished.
2. Description of work.
3. Total hours on aircraft.
4. Pilot certificate number.
5. Signature of pilot.

ALTERATIONS TO AIRCRAFT

The compactness and many unique design features of the R22 helicopter make any modification inadvisable. The dynamic characteristics and susceptibility to fatigue of the rotor, drive, and control systems make any modification to these systems extremely hazardous.

Also hazardous is installation of any electronic equipment or avionics not factory-approved and supplied. The compactness of the console and tunnel containing the controls and wire bundles makes installation of any additional wires likely to interfere with free control movement. The electronic tachometers and governor are affected by other electrical devices, and their reliability and accuracy are essential for safe operation of the helicopter. Installation of an electrical device not tested and approved by the factory could easily result in a hazardous condition.

Because of these potential hazards, Robinson Helicopter Company does not approve any modification or alteration other than those which are factory-supplied and installed by factory-trained personnel.

GROUND HANDLING

For leveling, hoisting, or jacking, see appropriate sections of the maintenance manual.

The helicopter is normally maneuvered on the ground using ground handling wheels.

To attach wheels:

1. Hold handle and wheel with protruding spindle in its lowest position.
2. Insert spindle into support mounted on skid. Make sure spindle is all the way in.
3. Pull handle over center to raise helicopter and lock wheel in position.

CAUTION

When lowering helicopter, handle has a tendency to snap over.

Move the helicopter by holding the tail rotor gearbox and aft tailcone section. If additional help is needed, a second person may push on one of the aft vertical frame tubes or on the nose.

CAUTION

Do not move helicopter by gripping vertical fins, outboard part of horizontal stabilizer, tail rotor, tail skid, or tail rotor controls.

PARKING

1. Place cyclic control in neutral and apply friction.
2. Put collective full down and apply friction.
3. Align rotor blades approximately fore and aft. In windy conditions, align blades slightly offset from fore and aft to prevent aft blade from flapping into tailcone. Apply rotor brake.
4. During storm conditions, helicopter should be hangared or moved to a safe area.

ENGINE OIL

Recommended maximum oil quantity is six quarts and minimum quantity for take-off is four quarts as indicated by the oil dipstick.

The oil and filter should be changed at least every 50 hours or four months, whichever occurs first. If no oil filter is installed, change oil every 25 hours.

To change oil:

1. Ground run or fly helicopter to obtain normal operating temperature.
2. Remove left side skirts. If heater is installed, it will be necessary to disconnect heater hose and blower motor ground wire and to remove bolt securing blower motor to frame. Open quick drain on bottom of sump to drain oil into suitable container.
3. Cut safety wire from oil suction screen cap located near centerline at accessory (magneto) end of sump. (Located on bottom of sump for O-320 engines.)
4. Remove, inspect, clean, and reinstall oil suction screen. Re-safety cap.
5. Cut safety wire from oil filter and break loose using wrench or loosen pressure-screen housing bolts.

ENGINE OIL (cont'd)

6. Place suitable container below and inboard of magneto to catch oil retained in filter or screen housing and remove filter or screen housing slowly to allow oil to drain into container. Do not allow oil to drain on magneto housing.
7. Cut filter open to inspect, or inspect and clean pressure screen.
8. Install new filter per instructions printed on filter and safety wire (use only Champion CH48108, CH48108-1, or Robinson B123-1 filter), or re-install pressure screen and housing. Torque pressure-screen housing bolts to 96 in-lb.
9. Close quick drain and fill sump with 6 quarts of appropriate grade oil as recommended below.
10. Start helicopter. Verify oil pressure within 30 seconds. Ground run for a few minutes, shut down, and verify no leaks.
11. Check oil level on dipstick.
12. Reinstall side skirts. Reinstall heater blower motor and heater hose if helicopter has heater.
13. Make appropriate maintenance record entries.

The following grades of oil are recommended:

Average Ambient Air Temperature	Mineral Grades MIL-L-6082 or SAEJ1966 (Use first 50 hours)	Ashless Dispersant Grades MIL-L-22851 or SAEJ1899 (Use after first 50 hours)
All Temperatures	—	SAE15W50 or SAE20W50
Above 80°F	SAE60	SAE60
Above 60°F	SAE50	SAE40 or SAE50
30°F to 90°F	SAE40	SAE40
0°F to 70°F	SAE30	SAE30, SAE40, or SAE20W40
0°F to 90°F	SAE20W50	SAE20W50 or SAE15W50
Below 10°F	SAE20	SAE30 or SAE20W30

TAIL ROTOR GEARBOX OIL

If oil is not visible in the sight gage with helicopter sitting level, oil must be added.

To add oil:

1. Cut safety wire and remove filler/vent cap located on top of gearbox.
2. Use only oil obtained from Robinson Helicopter and identified with part number A257-2.
3. Fill very slowly until oil is visible in sight gage. DO NOT overfill. (Less than a teaspoon of oil is usually required.)
4. Reinstall filler/vent cap. Be sure gasket is in place.
5. Safety wire as before. Be sure safety wire applies tension in direction which would tighten cap.

FUEL

Approved fuel grades and fuel capacity are given in Section 2.

A small quantity of fuel should be drained from the gascolator and from each tank using the quick drains prior to the first flight each day. Drain enough fuel to remove any water or dirt and check for approved fuel color. If fuel contamination is suspected, continue to drain fuel from gascolator and tank drains until all contamination is eliminated.

BATTERY

The battery is located either in the engine compartment or in the nose beneath the instrument console. To access the nose battery, remove the hold down screws (one on each side of console) and raise the instrument console. The battery is sealed and does not require fluid level checks.

CAUTION

Batteries can give off a gas which is flammable and explosive. Keep open flames or electric sparks away from battery. Do not smoke near battery. Batteries also contain acid which can cause personal injury, particularly to eyes. Protect eyes, face, and other exposed areas when working near a battery.

A discharged battery is NOT AIRWORTHY because it will not have the reserve capacity to operate the electrical system should the charging system fail in flight.

Often, a 10 or 15 minute charge will improve battery condition enough to start the engine. If battery is located in the engine compartment, first connect positive charger cable to positive (battery side) battery relay terminal. Then, connect negative charger cable to battery ground strap or engine. If battery is located in the nose, lift console, remove battery box cover, and connect charger cables directly to battery posts. For nose batteries, use extreme caution not to short to console sheet metal.

After charging, disconnect cables (disconnect negative cable first), secure console if opened, and attempt a normal start. If battery still has insufficient charge to start engine, service or replace before further flight.

CLEANING HELICOPTER

CLEANING EXTERIOR SURFACES

The helicopter should be washed with a mild soap and water. Harsh abrasives, alkaline soaps, or detergents could scratch painted or plastic surfaces or could cause corrosion of metal. Cover areas where cleaning solution could cause damage. Use the following procedure:

1. Rinse away loose dirt with water.
2. Apply cleaning solution with a soft cloth, sponge, or soft bristle brush.
3. To remove stubborn oil and grease, use a cloth dampened with aliphatic naphtha.
4. Rinse all surfaces thoroughly.
5. Any good automotive wax may be used to preserve painted surfaces. Soft cleaning cloths or a chamois should be used to prevent scratches when cleaning or polishing.

CAUTION

Never use high-pressure spray to clean helicopter. Never blow compressed air into main or tail rotor blade tip drain holes.

CLEANING HELICOPTER (cont'd)

CLEANING WINDSHIELD AND WINDOWS

1. Remove dirt, mud, and other loose particles from exterior surfaces with clean water.
2. Wash with mild soap and warm water or with aircraft plastic cleaner. Use a soft cloth or sponge in a straight back and forth motion. Do not rub harshly.
3. Remove oil and grease with a cloth moistened with isopropyl alcohol (rubbing alcohol) or aliphatic naphtha.

CAUTION

Do not use gasoline, other alcohols, benzene, carbon tetrachloride, thinner, acetone or window (glass) cleaning sprays.

4. After cleaning plastic surfaces, apply a thin coat of hard polishing wax. Rub lightly with a soft cloth. Do not use a circular motion.
5. Scratches can be removed by rubbing with jeweler's rouge followed by hand polishing with commercial plastic polish. Use a figure eight motion when polishing.

CLEANING HELICOPTER (cont'd)

CLEANING UPHOLSTERY AND SEATS

1. Vacuum and brush, then wipe with damp cloth. Dry immediately.
2. Soiled upholstery, except leather, may be cleaned with a good upholstery cleaner suitable for the material. Follow manufacturer's instructions. Avoid soaking or harsh rubbing.

CAUTION

If CO detector is installed, avoid use of solvents, detergents, or aerosol sprays near sensor. Tape off openings in top and bottom of sensor housing when cleaning cabin interior.

3. Leather should be cleaned with saddle soap or a mild hard soap and water.

CLEANING CARPETS

Remove loose dirt with a whisk broom or vacuum. For soiled spots and stains, use nonflammable dry cleaning liquid.

SECTION 9

SUPPLEMENTS

GENERAL

This section contains information in the form of supplements which are necessary for the safe and efficient operation of the helicopter when one or more of the following optional systems or equipment are installed.

The information contained in the supplements applies only when the related equipment is installed.

CONTENTS

Title	Supplement Number
R22 Police Version.	3
R22 Mariner/Mariner II	4

Supplement Numbers 1, 2, 5, 6, 7, and 8 are obsolete.

INTENTIONALLY BLANK

FAA APPROVED
R22 PILOT'S OPERATING HANDBOOK
SUPPLEMENT 3
TO
ROBINSON MODEL R22

This supplement must be attached to the FAA Approved Robinson R22 Pilot's Operating Handbook when the helicopter is configured with optional police version equipment.

The information contained herein supplements or supersedes the basic manual only in those areas listed in this Supplement. For limitations, procedures, and performance information not contained in this Supplement, consult the basic R22 Pilot's Operating Handbook.

FAA APPROVED *James M. Kingbee*
Supervisor, Flight Test Section
FAA, Western Aircraft Certification Field Office
Northwest Mountain Region

DATE *March 27, 1984*

LOG OF REVISIONS	
Page No.	Approval Date
9-3.1	04 Nov 1994
9-3.2	18 Dec 1987
9-3.3	04 Nov 1994
9-3.4	04 Nov 1994
9-3.5	04 Nov 1994
9-3.6	04 Nov 1994

REVISIONS
APPROVED BY *Donald Amundson*
Manager, Flight Test Branch ANM-160L
Federal Aviation Administration, LAACO
Transport Airplane Directorate

DATE *Nov. 4, 1994*

SECTION 9
R22

POLICE VERSION

INTRODUCTION

This supplement contains the changes and additional data applicable when the R22 helicopter is equipped with Police Version options.

SECTION 2: Limitations

VFR operation at night is permitted with either landing lights or searchlight operable. Instrument and anti-collision lights must be installed and operable.

SECTION 3: Emergency Procedures

No change.

SECTION 4: Normal Procedures

Additions to preflight check.

Add to number 10, fuselage left side.

PA Speaker secure

Searchlight secure

SECTION 5: Performance

No change.

SECTION 6: Weight & Balance

No change.

SECTION 7: Systems Description

The following optional equipment may be installed:

Airframe

Cabin doors with bubble windows to enhance downward and rearward visibility replace the standard doors.

Electrical System

A 14-volt, 70-ampere alternator replaces the standard 60-ampere unit.

Searchlight Installation

The searchlight installation consists of two lamps suspended below the cabin chin on a post which extends through the left hand side of the chin and cabin floor. The searchlight is controlled by means of a grip and switch(es) mounted on the post allowing operation by the passenger or pilot. Power is supplied to the searchlight through its own 20 amp circuit breaker and power relay. The searchlight will operate only when the landing lights are off. A friction control is located on the post just above the floor.

Two searchlight installations are available: one manufactured by Collins Dynamics and the other by Peak Beam Systems. The Collins Dynamics unit uses incandescent quartz halogen lamps controlled by a single on-off toggle switch on the grip. The Peak Beam Systems unit uses xenon arc lamps controlled by four momentary toggle switches on the grip. These switches control on-off, strobe (rapidly flashing) mode, and beam spread from 1° spot to 40° flood.

CAUTION

When operating the searchlight with the left seat cyclic installed, caution should be exercised to prevent interference with the cyclic control.

SECTION 7: Systems Description (Cont'd)

PA System

A 100-watt Whelen PA speaker and siren is located on the aft, left landing gear strut. The PA system control panel is located on the instrument panel. It allows the pilot or observer to select either PA, radio, yelp, or siren for broadcast through the PA speaker.

Remote Radio Transmit Switch

A hand-held remote radio transmit switch plugs into the receptacle on the front of the left seat. This switch allows the left seat occupant to transmit when the left cyclic is removed.

Circuit Breaker Panel

The circuit breaker panel is shown in Figure 1.

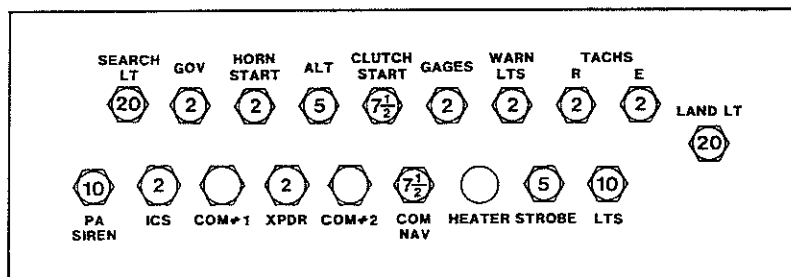

FIGURE 1

CIRCUIT BREAKER PANEL

SECTION 8: Handling and Maintenance

Searchlight Installation

To remove the searchlight from the helicopter, use the following procedure:

1. Loosen but do not remove two 1/4 in. diameter bolts in clamp on bottom end of post.
2. Remove clevis pin connecting lower end of tube through center of post to arms between lamps.
3. Disconnect wires from lamps at connectors on lamp housings.
4. Pull ring on spring loaded pin in post clamp and slide clamp with lamps off post.
5. Remove four screws holding post flange to cabin floor. Pull post up a few inches and disconnect wires at post connector. Before releasing, o-ring around the connector must be moved clear of retaining hooks. Pull post up and out of floor.
6. Cover connector under floor with tape and install sheet metal cover provided over hole in floor.

Installation is the reverse except:

1. Be sure to position o-ring on post wire connector under retaining hooks.
2. The letters "FWD" on post flange must face forward.
3. Be sure spring loaded pin in post clamp pops into place and torque 1/4 in. diameter bolts to 90 in.-lb (includes nut self-locking torque).

THIS PAGE INTENTIONALLY LEFT BLANK.

FAA APPROVED
R22 PILOT'S OPERATING HANDBOOK

SUPPLEMENT 4
R22 MARINER/MARINER II

This supplement must be attached to the FAA Approved Robinson R22 Pilot's Operating Handbook when the helicopter is configured in the Mariner or Mariner II version.

The information contained herein supplements or supersedes the basic manual only in those areas listed in this Supplement. For limitations, procedures, and performance information not contained in this Supplement, consult the basic R22 Pilot's Operating Handbook.

FAA APPROVED Frank J. Norman
Supervisor, Flight Test Section
FAA, Western Aircraft Certification Office
Northwest Mountain Region

DATE Sept 7, 1985

LOG OF REVISIONS

Page No.	Date	Page No.	Date
9-4.1	13 Oct 00	9-4.8	13 Oct 00
9-4.2	13 Oct 00	9-4.9	13 Oct 00
9-4.3	13 Oct 00	9-4.10	13 Oct 00
9-4.4	13 Oct 00	9-4.11	13 Oct 00
9-4.5	13 Oct 00	9-4.12	13 Oct 00
9-4.6	13 Oct 00	9-4.13	13 Oct 00
9-4.7	13 Oct 00		

REVISIONS
APPROVED BY Donald Armstrong
Manager, Flight Test Branch, ANM-160L
Federal Aviation Administration, LAACO
Transport Airplane Directorate

DATE Oct-13, 2000

SECTION 1: GENERAL

INTRODUCTION

This supplement contains the changes and additional data applicable for R22 Mariner and Mariner II helicopters. R22 Mariner/Mariner II helicopters are equipped with either float or standard landing gear, additional corrosion protection, and a modified horizontal stabilizer angle of incidence. Except as noted in this supplement, information in the basic manual pertaining to the R22 Beta is applicable to the R22 Mariner and information pertaining to the Beta II is applicable to the Mariner II.

Float landing gear consists of inflated floats attached to the skid tubes, and skid extensions to support the aft portion of the float tubes. When float landing gear is installed, an additional stabilizer is installed at the bottom of the lower vertical stabilizer for improved controllability. Configuration changes between float and standard landing gear are permitted.

SECTION 2: LIMITATIONS

AIRSPPEED LIMITATIONS

NEVER EXCEED AIRSPEED (V_{ne}) WITH FLOATS

Power-On: 95 KIAS up to 3000 ft density altitude.

Power-Off: 80 KIAS up to 7500 ft density altitude.

Above these density altitudes, see placard on page 9-4.4.

CENTER OF GRAVITY (CG) LIMITS

See figure on page 9-4.3. Datum line is 100 inches forward of main rotor shaft centerline.

KINDS OF OPERATION LIMITATIONS

Only VFR day is approved when floats are installed.

SECTION 2: LIMITATIONS (cont'd)

WITH FLOATS _____

WITHOUT FLOATS - - - - -

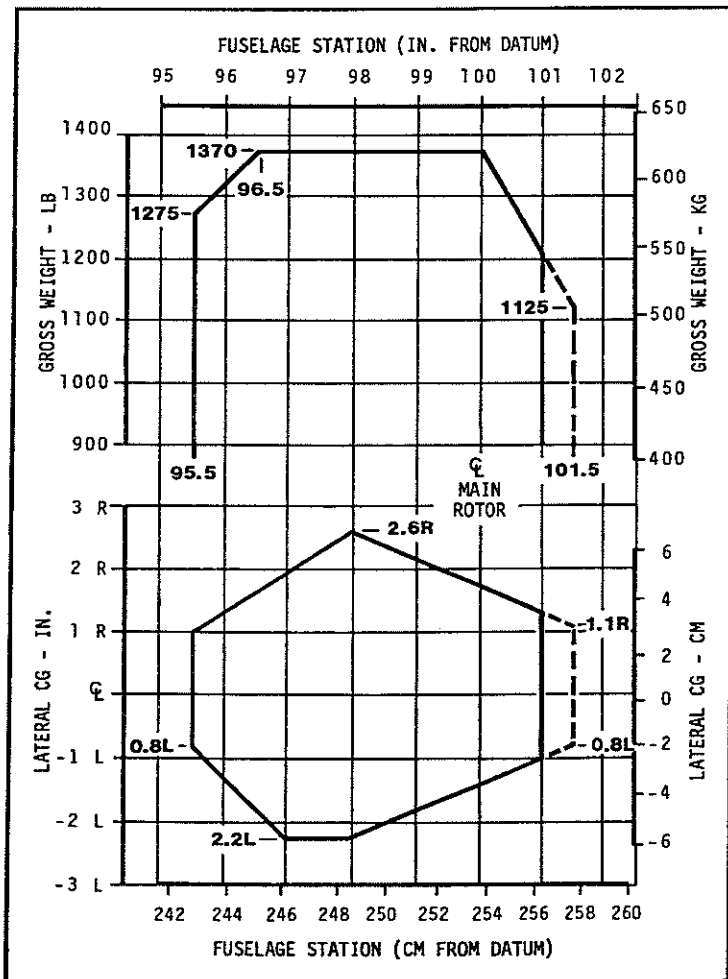

R22 MARINER/MARINER II
 CENTER OF GRAVITY LIMITS

SECTION 2: LIMITATIONS (cont'd)

PLACARDS

In clear view of pilot:

THIS ROTORCRAFT IS APPROVED FOR
DAY AND NIGHT VFR OPERATIONS
WITHOUT FLOATS INSTALLED
OR
DAY VFR OPERATIONS ONLY
WITH FLOATS INSTALLED

In clear view of pilot in flight:

R22 Mariner

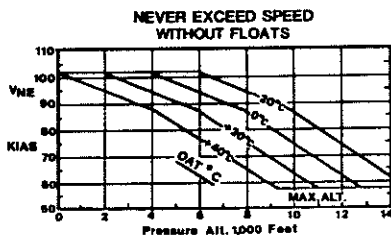
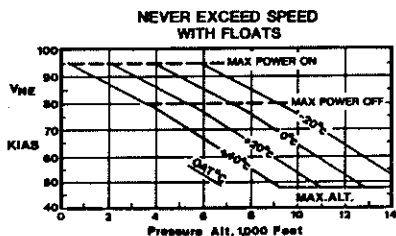

R22 Mariner II

**NEVER EXCEED SPEED - KIAS
WITH FLOATS**

PRESS	OAT - °C						
ALT-FT	-20	-10	0	10	20	30	40
SL							
2000		95			94	91	88
4000			94	90	86	83	79
6000		90	86	82	78	74	69
8000	86	82	77	72	67	62	57
10000	77	72	66	61	56	51	
12000	66	60	55				
14000	54						

NO FLIGHT

FOR AUTOROTATION, USE 80 KIAS ABOVE HEAVY LINE

**NEVER EXCEED SPEED - KIAS
WITHOUT FLOATS**

PRESS	OAT - °C						
ALT-FT	-20	-10	0	10	20	30	40
SL							
2000						99	96
4000					98	94	87
6000			98	94	87	82	77
8000	94	90	86	80	75	69	64
10000	86	80	74	68	62	57	
12000	74	67	61				
14000	61						

NO FLIGHT

Located on floats:

SEE PILOT'S HANDBOOK FOR
PROPER INFLATION PRESSURE

SECTION 2: LIMITATIONS (cont'd)

FLOAT PRESSURE LIMITS

Minimum Float Pressure: 2 psig (psi gage)

Maximum Float Pressure: 6 psig

The following graph shows minimum float pressure required for a decrease in altitude or temperature. An increase in either altitude or temperature can be ignored as pressure relief valves will limit pressure to 6 psig.

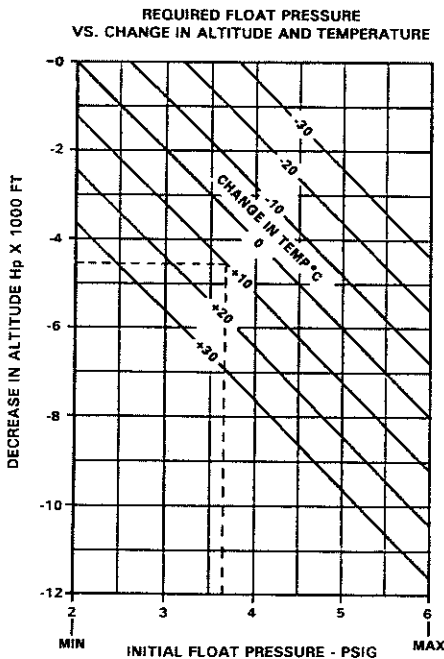

CAUTION

Failure to maintain required pressure can result in inadequate buoyancy or in-flight instability.

SAMPLE CALCULATION:

	Pressure	Altitude	Temp
Conditions at destination:		1000 ft	15°C
Initial Conditions:		5500 ft	5°C
Subtract to obtain expected change in altitude and temp:		-4500 ft	+10°C

Using graph, locate -4500 ft line, read across to +10°C line, then down for minimum initial float pressure required, approximately 3.7 psig.

SECTION 3: EMERGENCY PROCEDURES

GENERAL

Without floats, emergency procedures in the basic manual apply. The following procedures are applicable when floats are installed.

POWER FAILURE ABOVE 500 FEET AGL

Autorotation to Land: Same as non-float R22.

Autorotation to Water: Steps 1-7 same as non-float R22.

8. At about 8 feet AGL, apply forward cyclic to level helicopter and raise collective just before touchdown to cushion landing. Touchdown in slight nose high attitude with nose straight ahead.
9. Maintain cyclic in touchdown position and hold collective up until forward motion has stopped. See caution below.

POWER FAILURE BETWEEN 8 AND 500 FEET AGL

Autorotation to Land: Same as non-float R22.

Autorotation to Water: Steps 1-4 same as non-float R22.

5. At about 8 feet AGL, apply forward cyclic to level helicopter and raise collective just before touchdown to cushion landing. Touchdown in slight nose high attitude with nose straight ahead.
6. Maintain cyclic in touchdown position and hold collective up until forward motion has stopped.

CAUTION

Lowering collective or applying forward cyclic while helicopter is moving forward on water can cause floats to submerge and helicopter to nose over.

DITCHING

Not applicable when floats are installed.

SECTION 4: NORMAL PROCEDURES

DAILY OR PREFLIGHT CHECKS

14. Inflatable Floats

Float Pressure Check (See Section 2)

Float Condition Check

CAUTION

Helicopters equipped with inflated floats have an adverse roll characteristic; when sideslipping nose left or right the helicopter will tend to roll in the opposite direction. To avoid adverse roll, keep helicopter trimmed with zero sideslip and exercise extreme caution when performing simulated power failures.

OPERATION ON WATER

Maximum recommended water taxi speed is 5 knots. Some application of collective is required.

CAUTION

If starting or stopping rotor on water, ensure area is clear as helicopter can rotate one complete turn while tail rotor RPM is low.

CAUTION

To avoid contacting rotor teeter stops, do not apply full cyclic control during water taxi.

NOTE

Safe operation on water has been demonstrated in waves up to 12 inches (trough to crest).

SECTION 4: NORMAL PROCEDURES (cont'd)

PRACTICE AUTOROTATION - WITH GROUND CONTACT

Same as non-float R22 except rear of floats may be scuffed on pavement during touchdown. Protective tape should be applied to bottom of floats and inspected for wear after touchdowns.

PRACTICE AUTOROTATION - WITH WATER CONTACT

Same as practice autorotation with ground contact in basic manual except touch down in slight nose high attitude with nose straight ahead. Maintain cyclic in touchdown position and collective up until forward motion has stopped.

CAUTION

Lowering collective or applying forward cyclic while helicopter is moving forward on water can cause floats to submerge and helicopter to nose over.

SECTION 5: PERFORMANCE

HOVER PERFORMANCE

In-ground-effect (IGE) and out-of-ground-effect (OGE) hover performance charts for the R22 Mariner are on pages 9-4.9 and 9-4.10.

R22 Mariner II hover performance is equivalent to R22 Beta II hover performance.

IN GROUND EFFECT AT 2 FOOT SKID CLEARANCE
FULL THROTTLE AND 104% RPM

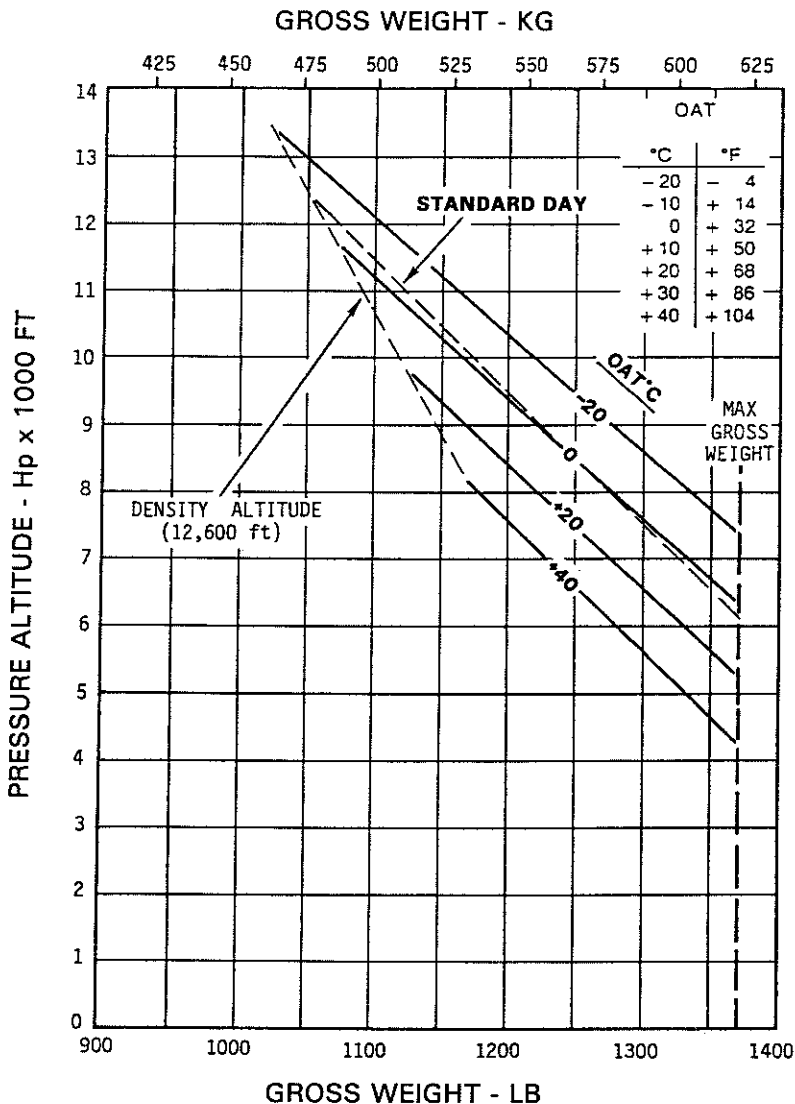

OUT OF GROUND EFFECT
TAKEOFF POWER OR FULL THROTTLE AT 104% RPM

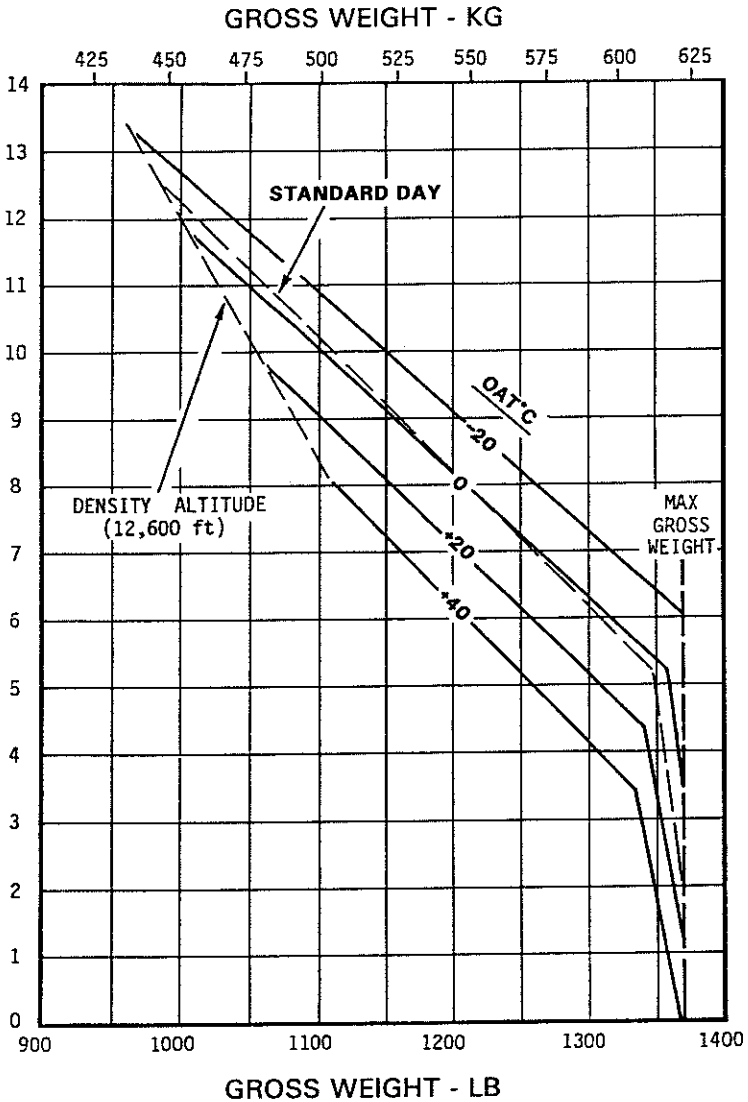

R22 MARINER
O-320-B2C Engine
5 Minute Takeoff Rating
OGE HOVER CEILING VS. GROSS WEIGHT

SECTION 6: WEIGHT AND BALANCE

CAUTION

When changing from float-equipped to non-float configuration or vice versa, weight and balance for basic helicopter must be revised and autorotation RPM readjusted per R22 Maintenance Manual.

WEIGHT AND BALANCE RECORD

Basic empty weight and CG in float and non-float configurations is included in the Weight and Balance Data provided with the helicopter. Modifications are to be recorded on page 6-5 of the basic manual.

LOADING INSTRUCTIONS

Determine loaded helicopter weights and moments per page 6-7. These values must fall within the Weight and Moment envelope shown below.

WITHOUT FLOATS WITH FLOATS

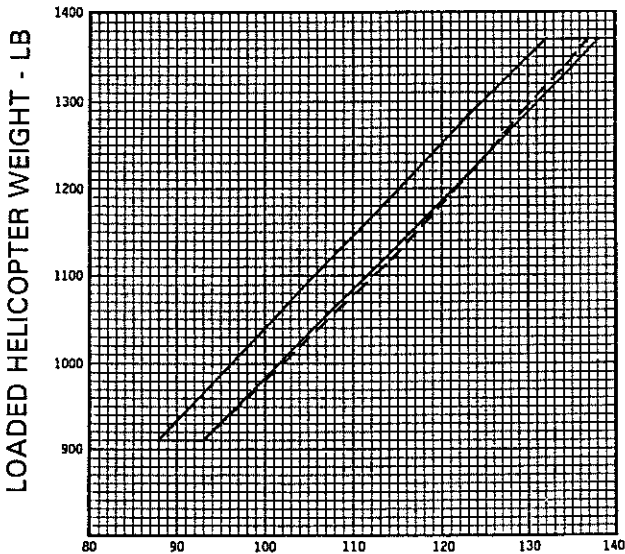

LOADED HELICOPTER MOMENT - 1000 inch-lbs.

R22 MARINER/MARINER II
Allowable CG Moment vs. Gross Weight Envelope

SECTION 7: SYSTEMS DESCRIPTION

No change.

SECTION 8: HANDLING, SERVICING AND MAINTENANCE

GROUND HANDLING

When floats are installed, special ground handling wheels are required. Refer to the R22 Maintenance Manual for wheel installation and removal procedures.

FLOAT TUBES

To promote long float tube life:

1. Do not inflate floats to a higher pressure than required in the Limitations section.
2. Do not arbitrarily inflate floats to the relief valve pressure.
- 3 Reduce pressure in floats if solar heating is causing an excessive pressure buildup.
4. Do not allow floats to sit uninflated for long periods of time, always maintain some pressure to keep shape when not in use.

CAUTION

When inflating chambers individually (without the use of a manifold), increase pressure in each chamber in 0.5 psig increments.

SECTION 10: SAFETY TIPS

Flight characteristics and handling qualities of a helicopter with inflated floats are more critical than those for helicopters with conventional landing gear. For instance, helicopters with floats installed have an adverse roll characteristic, i.e. when sideslipping nose right or left, the helicopter will tend to roll in the opposite direction out of the turn. This could be extremely dangerous if a student or instructor failed to put in right pedal or put in the wrong pedal during a simulated power failure. Also, aerodynamic lift produced by the floats makes both RPM and longitudinal attitude control more difficult during autorotation entries. Helicopters with floats installed are also more gust sensitive and therefore more difficult to fly in turbulence.

For these reasons, it is strongly recommended that floats be removed and standard gear installed when the helicopter is being used for primary flight instruction. When floats are installed, pilots must keep the helicopter trimmed with zero sideslip and exercise extreme caution when performing simulated power failures.

INTENTIONALLY BLANK

**SECTION 10
SAFETY TIPS AND NOTICES
CONTENTS**

	Page
General	10-1
Safety Tips	10-1
Safety Notices	SN-1 and Subsequent

INTENTIONALLY BLANK

**SECTION 10
SAFETY TIPS**

GENERAL

This section provides miscellaneous suggestions to help the pilot operate the helicopter more safely.

SAFETY TIPS

1. Never push the cyclic forward to descend or to terminate a pull-up (as you would in an airplane). This may produce a low-G (near weightless) condition which can result in a main rotor blade striking the cabin. Always use the collective to initiate a descent.
2. Never intentionally allow the fuel quantity to become so low in flight that the low warning light comes on.
3. Never leave the helicopter unprotected where curious onlookers may inadvertently damage critical parts, such as the tail rotor blades.
4. Turn the strobe light on before engaging the drive system and leave it on until the rotors stop turning. The strobe light is located near the tail rotor and provides a warning to ground personnel. Leaving it on in flight is also advisable since the helicopter may be difficult for other aircraft to see.
5. Never carry an external load except when using an approved hook, nor attach anything to the outside of the helicopter. Also be sure no loose articles are in the cabin, particularly when flying with any of the doors removed. Even a small object or piece of cloth or paper could damage the tail rotor if it comes loose in flight.
6. Avoid abrupt control inputs or accelerated maneuvers, particularly at high speed. These produce high fatigue loads in the dynamic components and could cause a premature and catastrophic failure of a critical component.

SAFETY TIPS (cont'd)

7. A change in the sound or vibration of the helicopter may indicate an impending failure of a critical component. Make a safe landing and thoroughly inspect aircraft before flight is resumed. A good practice is to hover the helicopter close to the ground for a prolonged period and reinspect before resuming free flight.
8. Be sure ground personnel or onlookers don't walk into the tail rotor. The main blades can also be dangerous, particularly on a sloped surface where the bystander may be on higher ground than the helicopter.
9. Never allow rotor RPM to become dangerously low. Most hard landings will be survivable as long as the rotor keeps turning and is not allowed to stall.
10. Never make takeoffs or landings downwind, especially at high altitude. The resulting loss of translational lift can cause the aircraft to settle into ground obstacles.
11. A vertical descent or steep approach downwind can result in "settling with power." This happens when the rotor is settling in its own downwash and additional power won't stop the descent. Should this occur, reduce collective and lower the nose to increase airspeed. This can be very dangerous near the ground as the recovery results in a substantial loss of altitude.
12. The helicopter is stable on its landing gear as long as ground contact is made vertically or with the aircraft moving forward. Should ground contact be made with the helicopter moving rearward, tail damage and possibly a rollover could occur. Low time pilots and students should practice landings and hovering with the aircraft slowly moving forward.

SAFETY TIPS (cont'd)

13. When operating at higher altitudes (above 3,000 or 4,000 feet), the throttle is frequently wide open and the RPM must be controlled with the collective. The throttle/collective correlation is not effective under these conditions and the governor response rate is fairly slow, so extreme care must be taken to roll throttle off as the collective is lowered to prevent an overspeed.
14. Do not use collective pitch to slow rotor during shutdown. Collective pitch produces lift on the blades which can disengage the teeter hinge friction and allow the blades to strike the tailcone. Also, do not slow or stop rotors by grabbing tail rotor. Stopping or turning tail rotor by hand can damage tail rotor drive.
15. Never land in tall dry grass. The exhaust is low to the ground and very hot; a grass fire may be ignited.
16. Always check an area for wires or other obstructions before practicing autorotations.

THIS PAGE INTENTIONALLY LEFT BLANK.

SAFETY NOTICES

The following safety notices have been issued by Robinson Helicopter Company as a result of various accidents and incidents. Studying the mistakes made by other pilots will help you avoid making the same errors.

SAFETY NOTICE	TITLE
SN-1	Inadvertent Actuation of Mixture Control in Flight
SN-9	Many Accidents Involve Dynamic Rollover
SN-10	Fatal Accidents Caused by Low RPM Rotor Stall
SN-11	Low-G Pushovers - Extremely Dangerous
SN-13	Do Not Attach Items to the Skids
SN-15	Fuel Exhaustion Can Be Fatal
SN-16	Power Lines Are Deadly
SN-17	Never Exit Helicopter with Engine Running Hold Controls When Boarding Passengers Never Land in Tall Dry Grass
SN-18	Loss of Visibility Can Be Fatal Overconfidence Prevails in Accidents
SN-19	Flying Low Over Water is Very Hazardous
SN-20	Beware of Demonstration or Initial Training Flights
SN-22	Always Reduce Rate-of-Descent Before Reducing Airspeed
SN-23	Walking into Tail Rotor Can Be Fatal
SN-24	Low RPM Rotor Stall Can Be Fatal
SN-25	Carburetor Ice
SN-26	Night Flight Plus Bad Weather Can Be Deadly
SN-27	Surprise Throttle Chops Can Be Deadly
SN-28	Listen for Impending Bearing Failure Clutch Light Warning
SN-29	Airplane Pilots High Risk When Flying Helicopters
SN-30	Loose Objects Can Be Fatal
SN-31	Governor Can Mask Carb Ice
SN-32	High Winds or Turbulence
SN-33	Vee-Belts Turning Rotor During Engine Start-Up
SN-34	Photo Flights - Very High Risk
SN-35	Flying Near Broadcast Towers
SN-36	Overspeeds During Liftoff
SN-37	Exceeding Approved Limitations Can Be Fatal
SN-38	Practice Autorotations Cause Many Training Accidents
SN-39	Unusual Vibration Can Indicate a Main Rotor Blade Crack
SN-40	Postcrash Fires

INTENTIONALLY BLANK

Safety Notice SN-1

Issued: Jan 81 Rev: Feb 89; Jun 94

INADVERTENT ACTUATION OF MIXTURE CONTROL IN FLIGHT

Cases have been reported where a pilot inadvertently pulled the mixture control instead of the carb heat or other control, resulting in sudden and complete engine stoppage. The knobs are shaped differently and the mixture control has a guard which must be removed and a push-button lock which must be depressed before actuating. These differences should be stressed when checking out new pilots. Also, in the R22, it is a good practice to always reach around the left side of the cyclic control when actuating the lateral trim. This will lessen the chance of pulling the mixture control by mistake. Always use the small plastic guard which is placed on the mixture control prior to starting the engine and is not removed until the end of the flight when the idle cut-off is pulled. Replace the guard on the mixture control so it will be in place for the next flight.

If the mixture control is inadvertently pulled, lower the collective and enter autorotation. If there is sufficient altitude, push the mixture control in and restart the engine using the left hand. **DO NOT** disengage the clutch.

Safety Notices SN-2 thru SN-8 have been superseded or deleted.

Safety Notice SN-9

Issued: Jul 82 Rev: Jun 94

MANY ACCIDENTS INVOLVE DYNAMIC ROLLOVER

A dynamic rollover can occur whenever the landing gear contacts a fixed object, forcing the aircraft to pivot about the object instead of about its own center of gravity. The fixed object can be any obstacle or surface which prevents the skid from moving sideways. Once started, dynamic rollover cannot be stopped by application of opposite cyclic alone. For example, assume the right skid contacts an object and becomes the pivot point while the helicopter starts rolling to the right. Even with full left cyclic applied, the main rotor thrust vector will still pass on the left side of the pivot point and produce a rolling moment to the right instead of to the left. The thrust vector and its moment will follow the aircraft as it continues rolling to the right. Quickly applying down collective is the most effective way to stop a dynamic rollover.

To avoid a dynamic rollover:

- 1) Always practice hovering autorotations into the wind and never when the wind is gusty or over 10 knots.
- 2) Never hover close to fences, sprinklers, bushes, runway lights or other obstacles a skid could catch on.
- 3) Always use a two-step liftoff. Pull in just enough collective to be light on the skids and feel for equilibrium, then gently lift the helicopter into the air.
- 4) Do not practice hovering maneuvers close to the ground. Keep the skids at least five feet above the ground when practicing sideward or rearward flight.

Safety Notice SN-10

Issued: Oct 82 Rev: Feb 89; Jun 94

FATAL ACCIDENTS CAUSED BY LOW RPM ROTOR STALL

A primary cause of fatal accidents in light helicopters is failure to maintain rotor RPM. To avoid this, every pilot must have his reflexes conditioned so he will instantly add throttle and lower collective to maintain RPM in any emergency.

The R22 and R44 have demonstrated excellent crashworthiness as long as the pilot flies the aircraft all the way to the ground and executes a flare at the bottom to reduce his airspeed and rate of descent. Even when going down into rough terrain, trees, wires or water, he must force himself to lower the collective to maintain RPM until just before impact. The ship may roll over and be severely damaged, but the occupants have an excellent chance of walking away from it without injury.

Power available from the engine is directly proportional to RPM. If the RPM drops 10%, there is 10% less power. With less power, the helicopter will start to settle, and if the collective is raised to stop it from settling, the RPM will be pulled down even lower, causing the ship to settle even faster. If the pilot not only fails to lower collective, but instead pulls up on the collective to keep the ship from going down, the rotor will stall almost immediately. When it stalls, the blades will either "blow back" and cut off the tailcone or it will just stop flying, allowing the helicopter to fall at an extreme rate. In either case, the resulting crash is likely to be fatal.

No matter what causes the low rotor RPM, the pilot must first roll on throttle and lower the collective simultaneously to recover RPM before investigating the problem. It must be a conditioned reflex. In forward flight, applying aft cyclic to bleed off airspeed will also help recover lost RPM.

Safety Notice SN-11

Issued: Oct 82 Rev: Nov 00

LOW-G PUSHOVERS - EXTREMELY DANGEROUS

Pushing the cyclic forward following a pull-up or rapid climb, or even from level flight, produces a low-G (weightless) flight condition. If the helicopter is still pitching forward when the pilot applies aft cyclic to reload the rotor, the rotor disc may tilt aft relative to the fuselage before it is reloaded. The main rotor torque reaction will then combine with tail rotor thrust to produce a powerful right rolling moment on the fuselage. With no lift from the rotor, there is no lateral control to stop the rapid right roll and mast bumping can occur. Severe in-flight mast bumping usually results in main rotor shaft separation and/or rotor blade contact with the fuselage.

The rotor must be reloaded before lateral cyclic can stop the right roll. To reload the rotor, apply an immediate gentle aft cyclic, but avoid any large aft cyclic inputs. (The low-G which occurs during a rapid autorotation entry is not a problem because lowering collective reduces both rotor lift and rotor torque at the same time.)

Never attempt to demonstrate or experiment with low-G maneuvers, regardless of your skill or experience level. Even highly experienced test pilots have been killed investigating the low-G flight condition. Always use great care to avoid any maneuver which could result in a low-G condition. Low-G mast bumping accidents are almost always fatal.

NEVER PERFORM A LOW-G PUSHOVER!!

Safety Notice SN-12 has been superseded by SN-24

Safety Notice SN-13

Issued: Jan 83 Rev: Jun 94

DO NOT ATTACH ITEMS TO THE SKIDS

The landing gear strut elbows have cracked on several helicopters when the pilot attempted to carry an external load strapped to the landing gear skids. The landing gear is optimized to take high "up" loads. Consequently, it has very low strength in the opposite or "down" direction. Also, even a small weight attached to the landing gear may change the natural frequency enough to cause high loads due to inflight vibration. Do not attempt to carry any external load or object attached to the landing gear.

Safety Notice SN-14 has been superseded by SN-17, SN-27 and SN-28

Safety Notice SN-15

Issued: Aug 83 Rev: Jun 94

FUEL EXHAUSTION CAN BE FATAL

Many pilots underestimate the seriousness of fuel exhaustion. Running out of fuel is the same as a sudden total engine or drive system failure. When that occurs, the pilot must immediately enter autorotation and prepare for a forced landing. Refer to Section 3 of the Pilot's Operating Handbook under Power Failure. If autorotation is not entered immediately, the RPM will rapidly decay, the rotor will stall, and the results will likely be fatal. Serious or fatal accidents have occurred as a result of fuel exhaustion.

To insure this does not happen to you, observe the following precautions:

- 1) Never rely solely on the fuel gage or the low fuel warning light. These electromechanical devices have questionable reliability in any airplane or helicopter. Always record the hourmeter reading each time the fuel tanks are filled.
- 2) During your preflight:
 - a) Check the fuel level in the tanks visually.
 - b) Be sure the fuel caps are tight.
 - c) Drain a small quantity of fuel from each tank and the gascolator to check for water or other contamination.
- 3) Before takeoff:
 - a) Insure that the fuel valve is full on.
 - b) Be sure guard is placed on mixture control.
 - c) Plan your next fuel stop so you will have at least 20 minutes of fuel remaining.
- 4) In flight:
 - a) Continually check both hourmeter and fuel gages. If either indicates low fuel, LAND.
 - b) Always land to refuel before the main tank fuel gage reads less than 1/4 full.
 - c) NEVER allow the fuel quantity to become so low in flight that the low fuel warning light comes on.

Safety Notice SN-16

Issued: Apr 84 Rev: Jun 94

POWER LINES ARE DEADLY

Flying into wires, cables, and other objects is by far the number one cause of fatal accidents in helicopters. Pilots must constantly be on the alert for this very real hazard.

- * Watch for the towers; you will not see the wires in time.
 - * Fly directly over the towers when crossing power lines.
 - * Allow for the smaller, usually invisible, grounding wire(s) which are well above the larger more visible wires.
 - * Constantly scan the higher terrain on either side of your flight path for towers.
 - * Always maintain at least 500 feet AGL except during take-off and landing. By always flying above 500 feet AGL, you can virtually eliminate the primary cause of fatal accidents.
-

Safety Notice SN-17

Issued: Nov 84 Rev: Feb 89; Jun 94

NEVER EXIT HELICOPTER WITH ENGINE RUNNING

Several accidents have occurred when pilots momentarily left their helicopters unattended with the engine running and rotors turning. The collective can creep up, increasing both pitch and throttle, allowing the helicopter to lift off or roll out of control.

HOLD CONTROLS WHEN BOARDING PASSENGERS

It is important to firmly grip both cyclic and throttle while loading or unloading passengers with the engine running in case they inadvertently bump the controls or slide across the throttle, rolling it open.

NEVER LAND IN TALL DRY GRASS

The engine exhaust is very hot and can easily ignite tall grass or brush. One R22 was completely destroyed by fire after a normal landing in tall grass.

Safety Notice SN-18

Issued: Jan 85 Rev: Feb 89; Jun 94

LOSS OF VISIBILITY CAN BE FATAL

Flying a helicopter in obscured visibility due to fog, snow, low ceiling, or even a dark night can be fatal. Helicopters have less inherent stability and much faster roll and pitch rates than airplanes. Loss of the pilot's outside visual references, even for a moment, can result in disorientation, wrong control inputs, and an uncontrolled crash. This type of situation is likely to occur when a pilot attempts to fly through a partially obscured area and realizes too late that he is losing visibility. He loses control of the helicopter when he attempts a turn to regain visibility but is unable to complete the turn without visual references.

You must take corrective action before visibility is lost! Remember, unlike the airplane, the unique capability of the helicopter allows you to land and use alternate transportation during bad weather, provided you have the good judgement and necessary willpower to make the correct decision.

OVERCONFIDENCE PREVAILS IN ACCIDENTS

A personal trait most often found in pilots having serious accidents is overconfidence. High-time fixed-wing pilots transitioning into helicopters and private owners are particularly susceptible. Airplane pilots feel confident and relaxed in the air, but have not yet developed the control feel, coordination, and sensitivity demanded by a helicopter. Private owners are their own boss and can fly without discipline, enforced rules, or periodic flight checks and critique by a chief pilot. A private owner must depend on self-discipline, which is sometimes forgotten.

When flown properly and conservatively, helicopters are potentially the safest aircraft built. But helicopters are also probably the least forgiving. They must always be flown defensively. The pilot should allow himself a greater safety margin than he thinks will be necessary, just in case.

Safety Notice SN-19

Issued: Jul 85 Rev: Jun 94

FLYING LOW OVER WATER IS VERY HAZARDOUS

Many helicopter accidents have occurred while maneuvering low over water. Many pilots do not realize their loss of depth perception when flying over water. Flying over calm glassy water is particularly dangerous, but even choppy water, with its constantly varying surface, interferes with normal depth perception and may cause a pilot to misjudge his height above the water.

MAINTAIN 500 FEET AGL WHENEVER POSSIBLE AND AVOID MANEUVERS OVER WATER BELOW 200 FEET AGL.

Safety Notice SN-20

Issued: Sep 85 Rev: Jun 94

BEWARE OF DEMONSTRATION OR INITIAL TRAINING FLIGHTS

A disproportionate number of fatal and non-fatal accidents occur during demonstration or initial training flights. The accidents occur because individuals other than the pilot are allowed to manipulate the controls without being properly prepared or indoctrinated.

If a student begins to lose control of the aircraft, an experienced flight instructor can easily regain control provided the student does not make any large or abrupt control movements. If, however, the student becomes momentarily confused and makes a sudden large control input in the wrong direction, even the most experienced instructor may not be able to recover control. Instructors are usually prepared to handle the situation where the student loses control and does nothing, but they are seldom prepared for the student who loses control and does the wrong thing.

Before allowing someone to touch the controls of the aircraft, they must be thoroughly indoctrinated concerning the extreme sensitivity of the controls in a light helicopter. They must be firmly instructed to never make a large or sudden movement with the controls. And, the pilot-in-command must be prepared to instantly grip the controls should the student start to make a wrong move.

Safety Notice SN-21 has been deleted.

Safety Notice SN-22

Issued: Jul 86 Rev: Jun 94

ALWAYS REDUCE RATE-OF-DESCENT BEFORE REDUCING AIRSPEED

Many helicopter accidents have been caused by the pilot reducing his airspeed to near zero during an approach before reducing his rate-of-descent. As the pilot then raises the collective and flares to stop his rate-of-descent, he flares into his own downwash, greatly increasing the power and collective pitch required. The aircraft begins to enter the vortex ring state (settling-with-power) and a hard landing occurs, often followed by a rollover. This can occur during a steep approach either power-on or power-off.

This can be avoided by always reducing your rate-of-descent before reducing your airspeed. A good rule to follow is never allow your airspeed to be less than 30 knots until your rate-of-descent is less than 300 feet per minute.

Safety Notice SN-23

Issued: Jul 86 Rev: Jun 94

WALKING INTO TAIL ROTOR CAN BE FATAL

Non-pilot passengers have been killed by inadvertently walking into a rotating tail rotor. Every possible precaution must be taken by the pilot to prevent this tragic type of accident. The following rules should always be observed:

- 1) Never allow anyone to approach the helicopter unless they are escorted or have been properly instructed. If necessary, shut down and stop rotors before boarding passengers.
- 2) Always have strobe light flashing when rotors are turning.
- 3) Instruct passengers to establish and maintain eye contact with pilot when approaching helicopter. (This will force them to approach only from the nose or side, never the tail).
- 4) Instruct passengers to leave the helicopter in full view of the pilot and walk only around the nose, never the tail.
- 5) Be especially careful when landing off airports as unseen children or adults might approach the helicopter from the rear.

THIS PAGE INTENTIONALLY LEFT BLANK.

Safety Notice SN-24

Issued: Sep 86 Rev: Jun 94

LOW RPM ROTOR STALL CAN BE FATAL

Rotor stall due to low RPM causes a very high percentage of helicopter accidents, both fatal and non-fatal. Frequently misunderstood, rotor stall is not to be confused with retreating tip stall which occurs only at high forward speeds when stall occurs over a small portion of the retreating blade tip. Retreating tip stall causes vibration and control problems, but the rotor is still very capable of providing sufficient lift to support the weight of the helicopter.

Rotor stall, on the other hand, can occur at any airspeed and when it does, the rotor stops producing the lift required to support the helicopter and the aircraft literally falls out of the sky. Fortunately, rotor stall accidents most often occur close to the ground during takeoff or landing and the helicopter falls only four or five feet. The helicopter is wrecked but the occupants survive. However, rotor stall also occurs at higher altitudes and when it happens at heights above 40 or 50 feet AGL it is most likely to be fatal.

Rotor stall is very similar to the stall of an airplane wing at low airspeeds. As the airspeed of an airplane gets lower, the nose-up angle, or angle-of-attack, of the wing must be higher for the wing to produce the lift required to support the weight of the airplane. At a critical angle (about 15 degrees), the airflow over the wing will separate and stall, causing a sudden loss of lift and a very large increase in drag. The airplane pilot recovers by lowering the nose of the airplane to reduce the wing angle-of-attack below stall and adds power to recover the lost airspeed.

The same thing happens during rotor stall with a helicopter except it occurs due to low rotor RPM instead of low airspeed. As the RPM of the rotor gets lower, the angle-of-attack of the rotor blades must be higher to generate the lift required to support the weight of the helicopter. Even if the collective is not raised by the pilot to provide the higher blade angle, the helicopter will start to descend until the

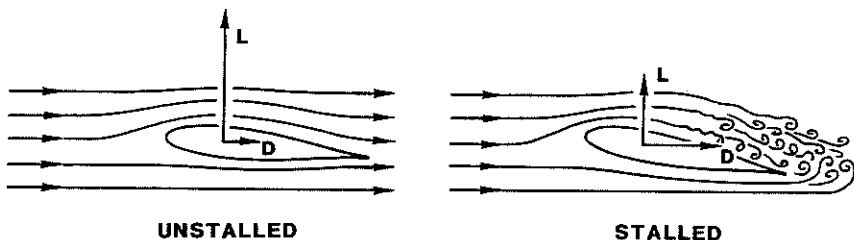

Wing or rotor blade unstalled and stalled.

Safety Notice SN-24 (continued)

upward movement of air to the rotor provides the necessary increase in blade angle-of-attack. As with the airplane wing, the blade airfoil will stall at a critical angle, resulting in a sudden loss of lift and a large increase in drag. The increased drag on the blades acts like a huge rotor brake causing the rotor RPM to rapidly decrease, further increasing the rotor stall. As the helicopter begins to fall, the upward rushing air continues to increase the angle-of-attack on the slowly rotating blades, making recovery virtually impossible, even with full down collective.

When the rotor stalls, it does not do so symmetrically because any forward airspeed of the helicopter will produce a higher airflow on the advancing blade than on the retreating blade. This causes the retreating blade to stall first, allowing it to dive as it goes aft while the advancing blade is still climbing as it goes forward. The resulting low aft blade and high forward blade become a rapid aft tilting of the rotor disc sometimes referred to as "rotor blow-back". Also, as the helicopter begins to fall, the upward flow of air under the tail surfaces tends to pitch the aircraft nose-down. These two effects, combined with aft cyclic by the pilot attempting to keep the nose from dropping, will frequently allow the rotor blades to blow back and chop off the tailboom as the stalled helicopter falls. Due to the magnitude of the forces involved and the flexibility of rotor blades, rotor teeter stops will not prevent the boom chop. The resulting boom chop, however, is academic, as the aircraft and its occupants are already doomed by the stalled rotor before the chop occurs.

Safety Notice SN-25

Issued: Dec 86 Rev: Nov 99

CARBURETOR ICE

Carburetor ice can cause engine stoppage and is most likely to occur when there is high humidity or visible moisture and air temperature is below 70°F (21°C). When these conditions exist, the following precautions must be taken:

During Takeoff - Unlike airplanes, which take off at wide open throttle, helicopters take off using only power as required, making them vulnerable to carb ice, especially when engine and induction system are still cold. Use full carb heat (it is filtered) during engine warm-up to preheat induction system and then apply carb heat as required during hover and takeoff to keep CAT gage out of yellow arc.

During Climb or Cruise - Apply carb heat as required to keep CAT gage out of yellow arc.

During Descent or Autorotation -

R22 - Below 18 inches manifold pressure, ignore CAT gage and apply full carb heat.

R44 - Apply carb heat as required to keep CAT gage out of yellow arc and full carb heat when there is visible moisture.

Safety Notice SN-26

Issued: Jan 87 Rev: Jun 94

NIGHT FLIGHT PLUS BAD WEATHER CAN BE DEADLY

Many fatal accidents have occurred at night when the pilot attempted to fly in marginal weather after dark. The fatal accident rate during night flight is many times higher than during daylight hours.

When it is dark, the pilot cannot see wires or the bottom of clouds, nor low hanging scud or fog. Even when he does see it, he is unable to judge its altitude because there is no horizon for reference. He doesn't realize it is there until he has actually flown into it and suddenly loses his outside visual references and his ability to control the attitude of the helicopter. As helicopters are not inherently stable and have very high roll rates, the aircraft will quickly go out of control, resulting in a high velocity crash which is usually fatal.

Be sure you NEVER fly at night unless you have clear weather with unlimited or very high ceilings and plenty of celestial or ground lights for reference.

Safety Notice SN-27

Issued: Dec 87 Rev: Jun 94

SURPRISE THROTTLE CHOPS CAN BE DEADLY

Many flight instructors do not know how to give a student a simulated power failure safely. They may have learned how to respond to a throttle chop themselves, but they haven't learned how to prepare a student for a simulated power failure or how to handle a situation where the student's reactions are unexpected. The student may freeze on the controls, push the wrong pedal, raise instead of lower the collective, or just do nothing. The instructor must be prepared to handle any unexpected student reaction.

Before giving a simulated power failure, carefully prepare your student and be sure you have flown together enough to establish that critical understanding and communication between instructor and student. Go through the exercise together a number of times until the student's reactions are both correct and predictable. Never truly surprise the student. Tell him you are going to give him a simulated power failure a few minutes before, and when you roll off the throttle, loudly announce "power failure". The manifold pressure should be less than 21 inches and the throttle should be rolled off smoothly, never "chopped". Follow through on all controls and tighten the muscles in your right leg to prevent the student from pushing the wrong pedal if he becomes confused. And always assume that you will be required to complete the autorotation entry yourself. Never wait to see what the student does. Plan to initiate the recovery within one second, regardless of the student's reaction.

There have been instances when the engine has quit during simulated engine failures. As a precaution, always perform the simulated engine failure within glide distance of a smooth open area where you are certain you could complete a safe touch-down autorotation should it become necessary. Also, never practice simulated power failures until the engine is thoroughly warmed up. Wait until you have been flying for at least 15 to 20 minutes.

Safety Notice SN-28

Issued: Jul 88 Rev: Jun 94

LISTEN FOR IMPENDING BEARING FAILURE

An impending ball or roller bearing failure is usually preceded by a noticeable increase in noise. The noise will almost always start at least several hours before the bearing actually fails and long before there is any increase in the bearing temperature. To detect a possible failure of a drive system bearing, the pilot should open his right door, uncover his right ear, and listen to the sound of the drive system both during start-up and during shutdown. After the pilot becomes familiar with the normal sound of the drive system, he should be able to detect the noise made by a failing bearing. The failing bearing will produce a loud whine, rumble, growl, or siren sound. Upon hearing an unusual noise, the pilot must immediately ground the aircraft and have the bearings thoroughly inspected by a qualified mechanic. Failure of a bearing in flight could result in a serious accident.

Do not rely on Telatemps. A failing bearing will not run hot enough to black out the Telatemps until it actually starts to disintegrate and is grinding steel on steel. This may occur only seconds before complete failure.

CLUTCH LIGHT WARNING

It is normal for the clutch light to occasionally come on while in flight for a short time (period varies between aircraft, but is usually not more than 3 or 4 seconds) to re-tension the vee-belts as they become warm and stretch slightly. However, if the clutch light flickers or stays on for a longer time than usual, it can indicate a belt or bearing failure in the vee-belt drive. If that occurs, immediately pull the CLUTCH circuit breaker. Select the closest safe landing site and make a normal power-on landing. Be prepared to enter autorotation should failure of the drive system occur. The smell of burning rubber may also indicate an impending belt failure.

After landing, perform a normal shutdown. Check the vee-belt drive to insure that the belts are in their grooves and not broken or deteriorating. Check the upper and lower actuator bearings for seal damage. Also check the Telatemp indicator readings. If there is seal damage or the temperature reading is unusually high have the aircraft inspected by a mechanic before further flight.

Safety Notice SN-29

Issued: Mar 93 Rev: Jun 94

AIRPLANE PILOTS HIGH RISK WHEN FLYING HELICOPTERS

There have been a number of fatal accidents involving experienced pilots who have many hours in airplanes but with only limited experience flying helicopters.

The ingrained reactions of an experienced airplane pilot can be deadly when flying a helicopter. The airplane pilot may fly the helicopter well when doing normal maneuvers under ordinary conditions when there is time to think about the proper control response. But when required to react suddenly under unexpected circumstances, he may revert to his airplane reactions and commit a fatal error. Under those conditions, his hands and feet move purely by reaction without conscious thought. Those reactions may well be based on his greater experience, i.e., the reactions developed flying airplanes.

For example, in an airplane his reaction to a warning horn (stall) would be to immediately go forward with the stick and add power. In a helicopter, application of forward stick when the pilot hears a horn (low RPM) would drive the RPM even lower and could result in rotor stall, especially if he also "adds power" (up collective). In less than one second the pilot could stall his rotor, causing the helicopter to fall out of the sky.

Another example is the reaction necessary to make the aircraft go down. If the helicopter pilot must suddenly descend to avoid a bird or another aircraft, he rapidly lowers the collective with very little movement of the cyclic stick. In the same situation, the airplane pilot would push the stick forward to dive. A rapid forward movement of the helicopter cyclic stick under these conditions would result in a low "G" condition which could cause mast bumping, resulting in separation of the rotor shaft or one blade striking the fuselage. A similar situation exists when terminating a climb after a pull-up. The airplane pilot does it with forward stick. The helicopter pilot must use his collective or a very gradual, gentle application of forward cyclic.

To stay alive in the helicopter, the experienced airplane pilot must devote considerable time and effort to developing safe helicopter reactions. The helicopter reactions must be stronger and take precedence over the pilot's airplane reactions because everything happens faster in a helicopter. The pilot does not have time to realize he made the wrong move, think about it, and then correct it. It's too late; the rotor has already stalled or a blade has already struck the airframe and there is no chance of recovery. To develop safe helicopter reactions, the airplane pilot must practice each procedure over and over again with a competent instructor until his hands and feet will always make the right move without requiring conscious thought. **AND, ABOVE ALL, HE MUST NEVER ABRUPTLY PUSH THE CYCLIC STICK FORWARD.**

Also see Safety Notices SN-11 and SN-24.

Safety Notice SN-30

Issued: Jun 94

LOOSE OBJECTS CAN BE FATAL

A recent fatal accident occurred when the pilot allowed her kneeboard to go out the left door and strike the tail rotor. Any loose object striking the tail rotor can cause failure of a tail rotor blade. Loss or damage of a tail rotor blade may cause a severe out-of-balance vibration which can separate the tail rotor gearbox or entire tail assembly from the tailcone, resulting in a catastrophic accident. R22 accidents have been caused by fuel caps, map cases, birds, and other objects striking the tail rotor. Before each flight perform the following:

- 1) Walk completely around the aircraft checking fuel caps, tail rotor, and for anything which could catch a skid, such as a connected static line.
- 2) Stow or secure all loose objects in the cabin.
- 3) Firmly latch all doors.
- 4) And, never fly with a left door removed. (Remove only the right door for ventilation.)

Safety Notice SN-31

Issued: Dec 96

GOVERNOR CAN MASK CARB ICE

With throttle governor on, carb ice will not become apparent as a loss of either RPM or manifold pressure. The governor will automatically adjust throttle to maintain constant RPM which will also result in constant manifold pressure. When in doubt, apply carb heat as required to keep CAT out of yellow arc during hover, climb, or cruise, and apply full carb heat when manifold pressure is below 18 inches.

Also remember, if carb heat assist is used it will reduce carb heat when you lift off to a hover and the control may require readjustment in flight.

Safety Notice SN-32

Issued: Mar 98

HIGH WINDS OR TURBULENCE

Flying in high winds or turbulence should be avoided but if unexpected turbulence is encountered, the following procedures are recommended:

- 1) Reduce airspeed to between 60 or 70 KIAS.
- 2) Tighten seat belt and firmly rest right forearm on right leg to prevent unintentional control inputs.
- 3) Do not overcontrol. Avoid large or abrupt control movements. Allow aircraft to go with the turbulence, then restore level flight with smooth gentle control inputs.
- 4) Leave governor on and do not chase RPM or airspeed. Momentary RPM or airspeed excursions are to be expected.
- 5) Avoid flying on the downwind side of hills, ridges, or tall buildings where the turbulence will likely be most severe.
- 6) Never fly into a blind or box canyon during high winds.

Safety Notice SN-33

Issued: Mar 98

VEE-BELTS TURNING ROTOR DURING ENGINE START-UP

New vee-belts on R22 or R44 helicopters may cause the rotor to turn during engine start. This places unnecessary load on starter and may produce high torsional stresses in drive train. The following procedure is recommended with new belts:

- 1) During shutdown, do not disengage clutch.
- 2) After master switch is off, put clutch switch in DISENGAGE position.
- 3) Prior to next flight, wait for clutch to disengage before starting engine.

Safety Notice SN-34

Issued: Mar 99

PHOTO FLIGHTS - VERY HIGH RISK

There is a misconception that photo flights can be flown safely by low time pilots. Not true. There have been numerous fatal accidents during photo flights, including several involving R22 helicopters.

Often, to please the photographer, an inexperienced pilot will slow the helicopter to less than 30 KIAS and then attempt to maneuver for the best picture angle. While maneuvering, the pilot may lose track of airspeed and wind conditions. The helicopter can rapidly lose translational lift and begin to settle. An inexperienced pilot may raise the collective to stop the descent. This can reduce RPM thereby reducing power available and causing an even greater descent rate and further loss of RPM. Rolling on throttle will increase rotor torque but not power available due to the low RPM. Because tail rotor thrust is proportional to the square of RPM, if the RPM drops below 80% nearly one-half of the tail rotor thrust is lost and the helicopter will rotate nose right. Suddenly the decreasing RPM also causes the main rotor to stall and the helicopter falls rapidly while continuing to rotate. The resulting impact is usually fatal.

Photo flights should only be conducted by well trained, experienced pilots who:

- 1) Have at least 500 hours pilot-in-command in helicopters and over 100 hours in the model flown;
- 2) Have extensive training in both low RPM and settling-with-power recovery techniques;
- 3) Are willing to say no to the photographer and only fly the aircraft at speeds, altitudes, and wind angles that are safe and allow good escape routes.

Please reread Safety Notice SN-24

Safety Notice SN-35

Issued: Apr 99

FLYING NEAR BROADCAST TOWERS

Electrical system malfunctions have occurred in aircraft, including R22 and R44 helicopters, when flying near high intensity broadcast towers. While transmission tower location and height are marked on aeronautical charts, transmitter power is not.

Early indications of a high power radio field include strong interference in the intercom system and aircraft radio receivers. Increasing field strength may cause random illumination of warning lights and erratic governor and tachometer operation. If the pilot has removed his hand from the collective to adjust the radio due to the interference, initial erratic operation of the governor may go unnoticed. Under these conditions, the governor may roll the throttle to idle or open it rapidly, overspeeding the engine and rotor.

The following precautions should be taken to reduce the risk from high power radio transmitters:

- 1) Do not fly near broadcast towers.
- 2) Do not become distracted trying to adjust the radio or intercom to reduce interference. Keep one hand on the collective and throttle, and be prepared to switch off the governor and assume manual throttle control.
- 3) Although permanent damage is unlikely, check electrical system thoroughly following a flight through a high power radio field.

Safety Notice SN-36

Issued: Nov 00

OVERSPEEDS DURING LIFTOFF

Helicopters have been severely damaged by RPM overspeeds during liftoff. The overspeeds caused a tail rotor drive shaft vibration which led to immediate failure of shaft and tailcone. Throughout the normal RPM range, tail rotor shaft vibration is controlled by damper bearing. However, damper is not effective above 120% RPM.

Mechanical correlation can cause overspeed during liftoff if RPM is increased to normal flight settings and collective raised before governor is switched on. Overspeeds can also occur if throttle is gripped too firmly during liftoff causing governor to be overridden. Inexperienced pilots, who are most likely to be nervous or distracted, are particularly susceptible to this type of overspeed.

To avoid overspeeds during liftoff:

1. Always confirm governor on before increasing RPM above 80%.
2. Verify governor stabilizes engine RPM near top of green arc.
3. Maintain relaxed grip on throttle allowing governor to control RPM.

Safety Notice SN-37

Issued: Dec 01

EXCEEDING APPROVED LIMITATIONS CAN BE FATAL

Many pilots do not understand metal fatigue. Each time a metal component is loaded to a stress level above its fatigue limit, hidden damage occurs within the metal. There is no inspection method which can detect this invisible fatigue damage. The first indication will be a tiny microscopic crack in the metal, often hidden from view. The crack will grow with each repetition of the critical stress until the part suddenly breaks. Crack growth will occur quite rapidly in drive system parts from the high frequency torsional loads. It will also occur rapidly in rotor system components due to the high centrifugal force on the blades and hub. Damaging fatigue cycles occur with every revolution of an overloaded drive shaft or rotor blade.

If a pilot exceeds the power or airspeed limits on a few occasions without failure, he may be misled into believing he can safely operate at those high loads. Not true. Every second the limitations are exceeded, more stress cycles occur and additional fatigue damage can accumulate within the metal. Eventually, a fatigue crack will begin and grow until a sudden failure occurs. If the pilot is lucky, the part will have reached its approved service life and be replaced before failure. If not, there will likely be a serious or fatal accident.

WARNING

- 1) Always operate the aircraft well below its approved Vne (never exceed speed), especially in turbulent wind conditions.
- 2) Do not operate the engine above its placarded manifold pressure limits.
- 3) Do not load the aircraft above its approved gross weight limit.
- 4) **The most damaging conditions occur when flying or maneuvering at high airspeeds combined with high power settings.**

Safety Notice SN-38

Issued: Jul 2003

Rev: Oct 2004

PRACTICE AUTOROTATIONS CAUSE MANY TRAINING ACCIDENTS

Each year many helicopters are destroyed practicing for the engine failure that very rarely occurs.

Many practice autorotation accidents occur when the helicopter descends below 100 feet AGL without all the proper conditions having been met. As the aircraft descends through 100 feet AGL, make an immediate power recovery unless all of the following conditions exist:

- 1) Rotor RPM in middle of green arc
- 2) Airspeed stabilized between 60 and 70 KIAS
- 3) A normal rate of descent, usually less than 1500 ft/min
- 4) Turns (if any) completed

Instructors may find it helpful to call out "RPM, airspeed, rate of descent" prior to passing through 100 feet. At density altitudes above 4000 feet, increase the decision point to 200 feet AGL or higher.

A high percentage of training accidents occur after many consecutive autorotations. To maintain instructor focus and minimize student fatigue, limit practice to no more than 3 or 4 consecutive autorotations.

There have been instances when the engine has quit during practice autorotation. To avoid inadvertent engine stoppage, do not roll throttle to full idle. Reduce throttle smoothly for a small visible needle split, then hold throttle firmly to override governor. Recover immediately if engine is rough or engine RPM continues to drop.

Safety Notice SN-39

Issued: Jul 2003

UNUSUAL VIBRATION CAN INDICATE A MAIN ROTOR BLADE CRACK

A catastrophic rotor blade fatigue failure can be averted if pilots and mechanics are alert to early indications of a fatigue crack. Although a crack may be internal to blade structure and not visible, it will likely cause a significant increase in rotor vibration prior to final failure. If a rotor is smooth after balancing but then goes out of balance again within a few flights, it should be considered suspect. Have the rotor system thoroughly examined by a qualified mechanic before further flight.

If main rotor vibration rapidly increases or becomes severe during flight, make an immediate safe landing. Do not attempt to continue flight to a convenient destination.

Safety Notice SN-40

Issued: Jul 2006

POSTCRASH FIRES

There have been a number of cases where helicopter or light plane occupants have survived an accident only to be severely burned by fire following the accident. To reduce the risk of injury in a postcrash fire, it is strongly recommended that a fire-retardant Nomex flight suit, gloves, and hood or helmet be worn by all occupants.